

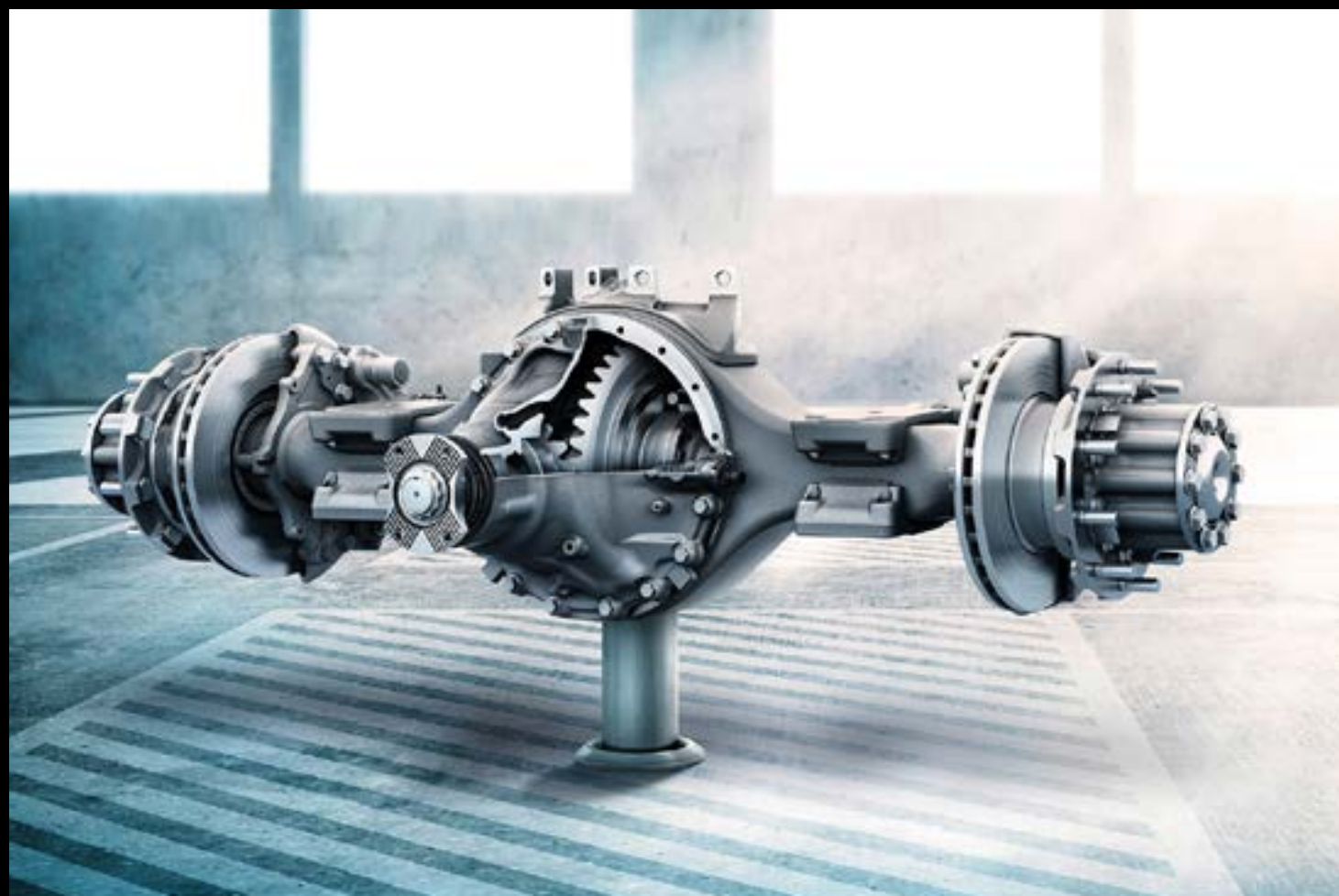

Mercedes-Benz Powertrain  
**TRANSMISSIONS AND AXLES**  
**FOR OFF-HIGHWAY SOLUTIONS.**

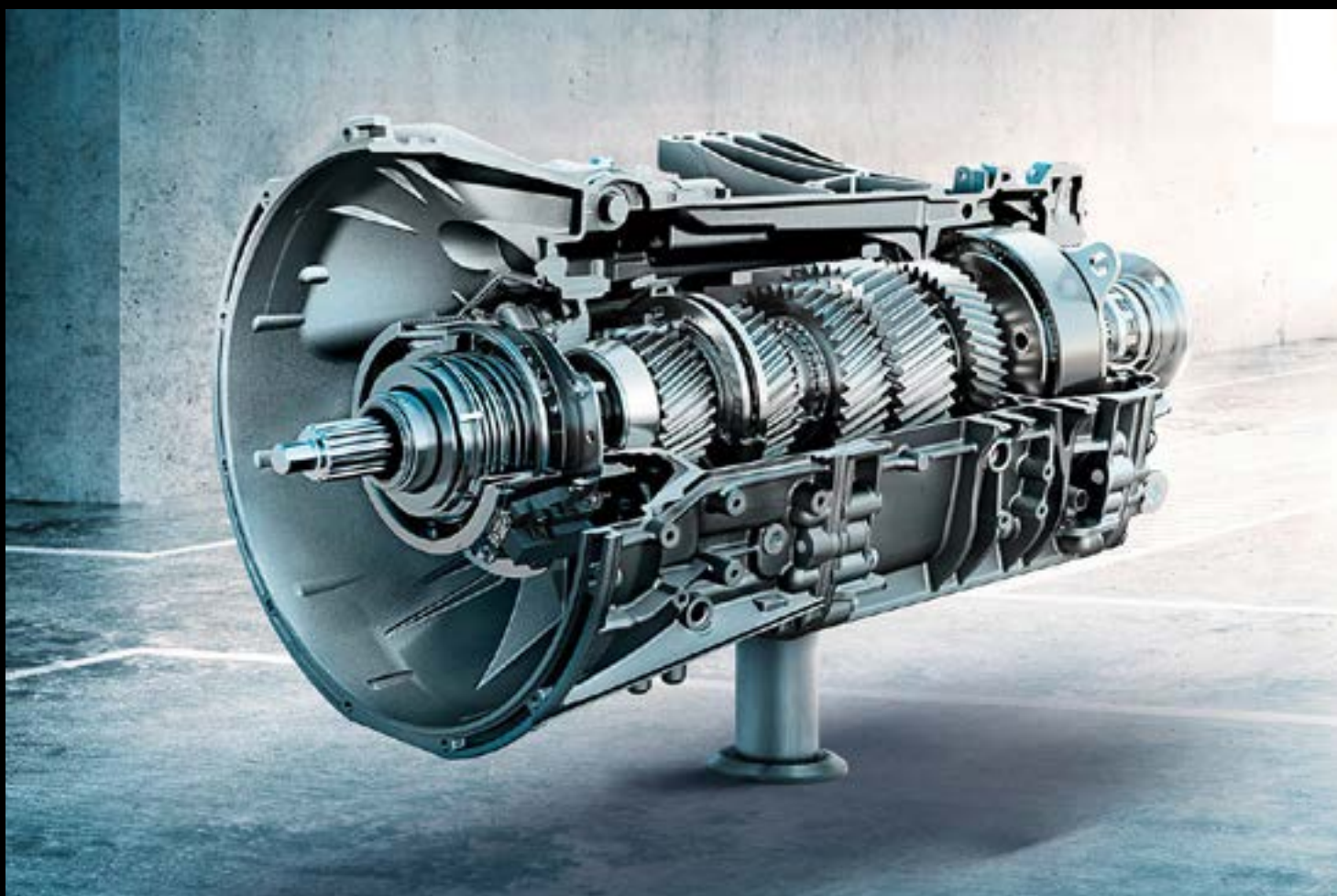

**Mercedes-Benz**  
Trucks you can trust



---

# OVERVIEW



---

# MERCEDES-BENZ POWERTRAIN

Global leader. In technology  
and efficiency.

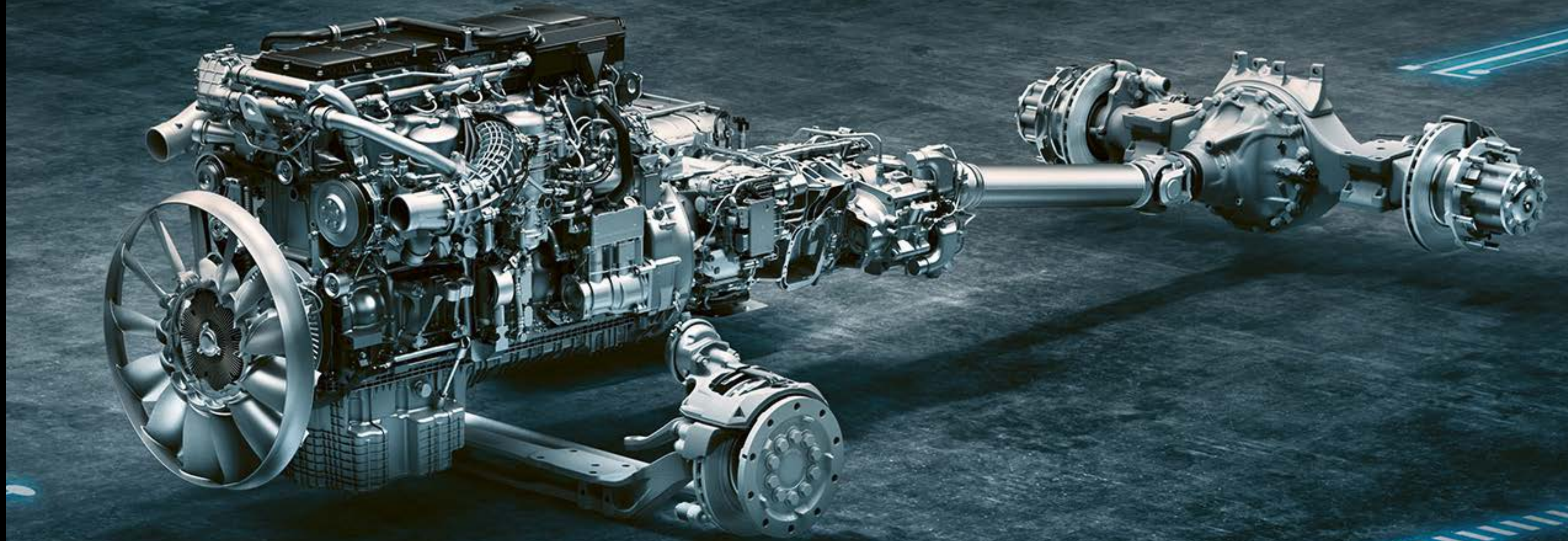

# BENEFITS FOR YOU. AND FOR YOUR CUSTOMERS.

**Mercedes-Benz Powertrain** offers you outperforming transmissions and axles for your individual Off-Highway applications. We provide you with the highest durability and proven quality made by Mercedes-Benz. The advanced technology results in very smooth running characteristics, low weight, superior fuel efficiency and durability.

## Benefits for you

- Premium Mercedes-Benz quality standards from our high-volume productlines.
- High investment in Mercedes-Benz R&D ensures state-of-the-art product characteristics.
- Overall robust and reliable solutions provide a long lifetime.
- All in one: only one supplier for your individual transmission and axle solution.
- Fixed contact person: one Key Account Manager as main contact partner and one contractual partner.

## Benefits for your customers

- Robust and reliable performance in every scenario of operation.
- Increased resale value of the vehicles due to the highest quality standards by Mercedes-Benz.
- Minimised downtime as our worldwide aftersales network covers warranty and policy.
- Best spare parts supply and technology by Mercedes-Benz.

---

# TRANSMISSIONS

Reliable transmissions  
for a wide range of applications.

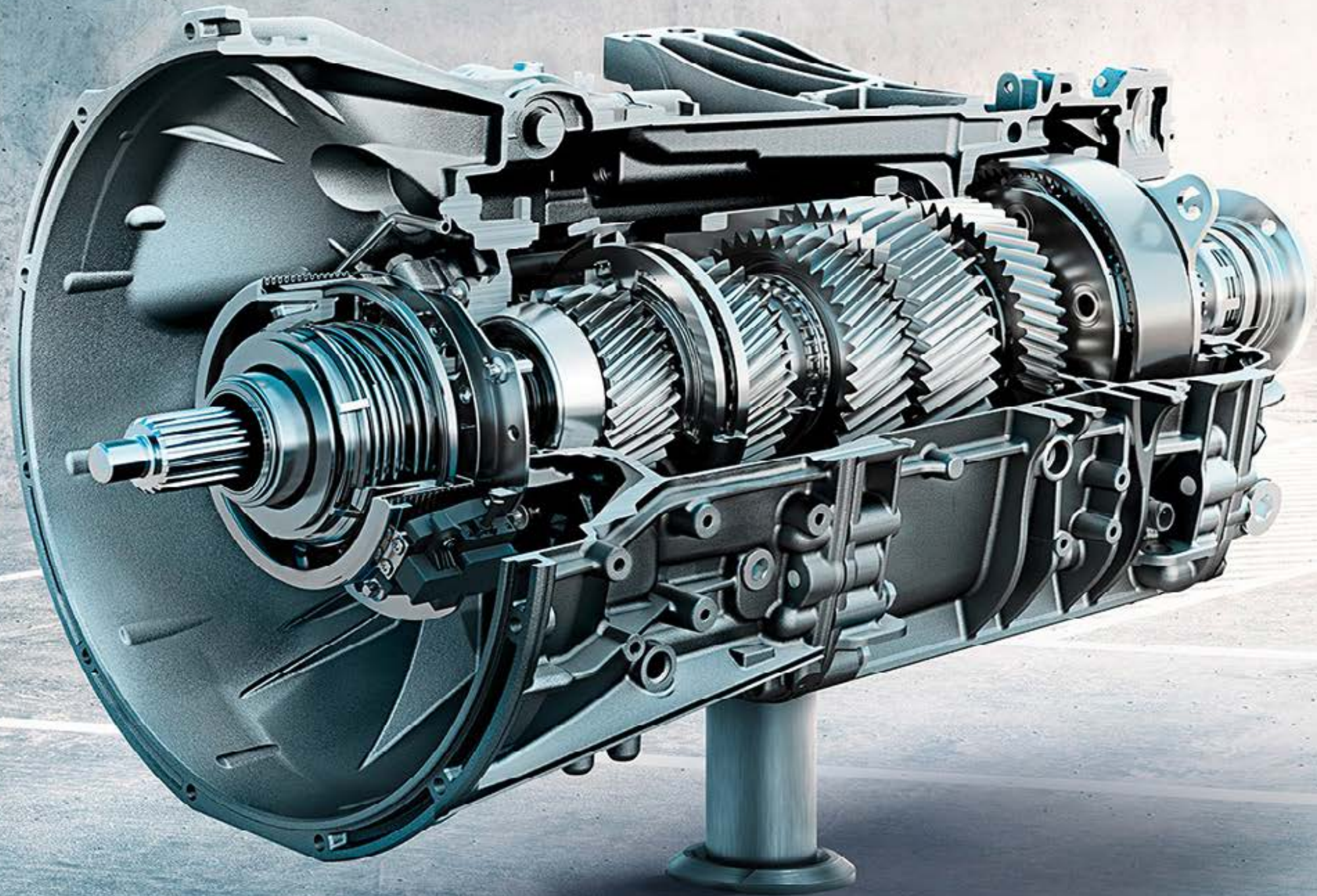

# SMOOTH AND EFFICIENT OPERATION IN EVERY SITUATION.

Our range of service extends from 12-speed to 16-speed transmissions for heavy-duty special vehicles and mobile cranes. An extensive selection of power take-off units, transfer cases and various circuit variants ensure that a custom-made transmission can be developed from standardized components. All transmissions are manufactured on a large scale by Mercedes-Benz Commercial Vehicles and are engineered to meet the highest standards of technology and quality.

Meeting the demands of our customers is the focus of our work. We feel committed to advancing the design of our systems in a consistent and innovative way in line with market and customer requirements.

Our know-how is based on decades of experience in the manufacturing and development of commercial vehicle transmissions. This manufacturing expertise distinguishes our transmissions today through three features in particular:

- **Very smooth running characteristics**
- **Low weight**
- **Extreme durability**

In future, we will continue to stand for innovative products focused on customer-oriented applications.

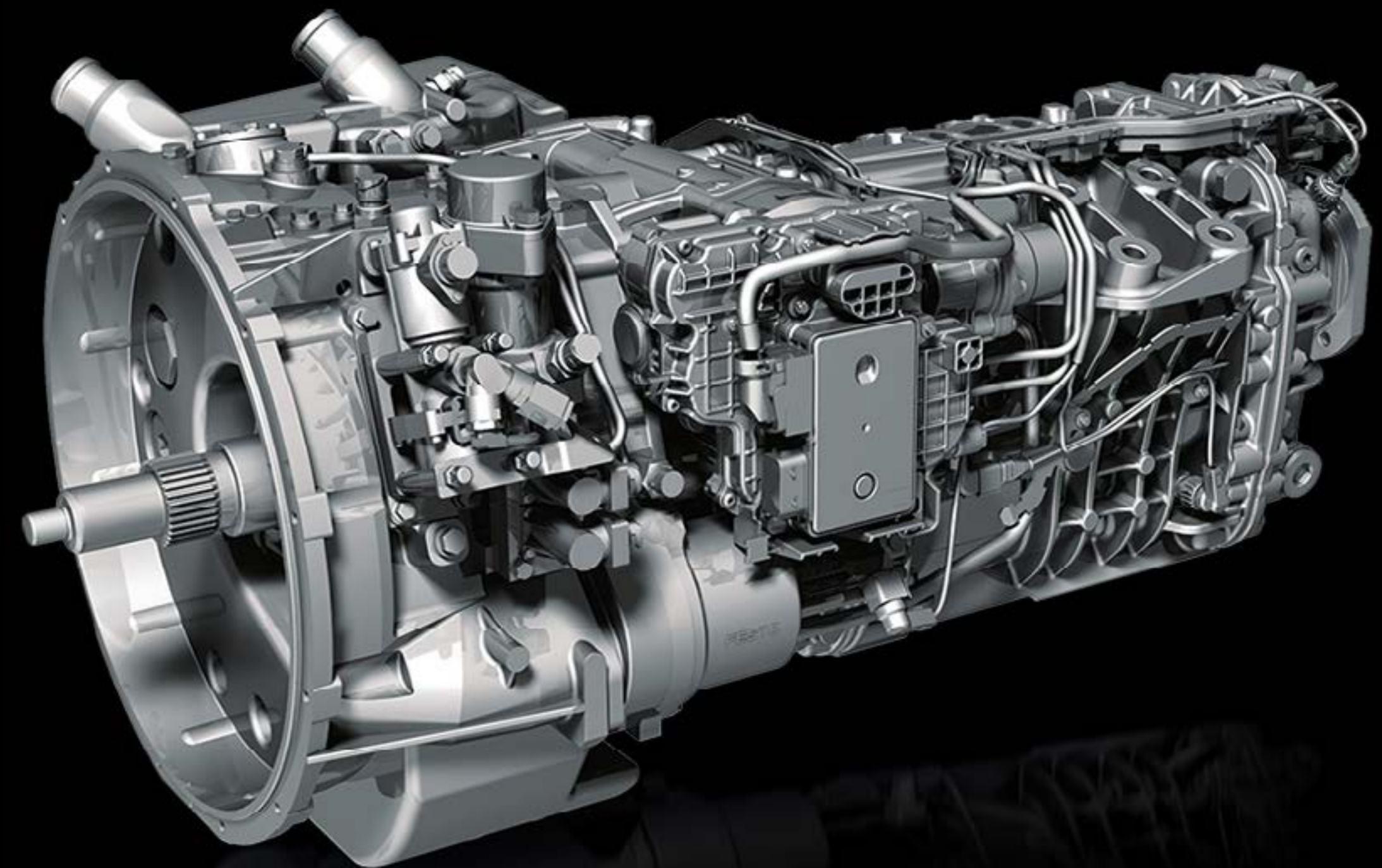

# TRANSMISSIONS FOR EURO VI ENGINE SYSTEMS.

## Portfolio of transmissions

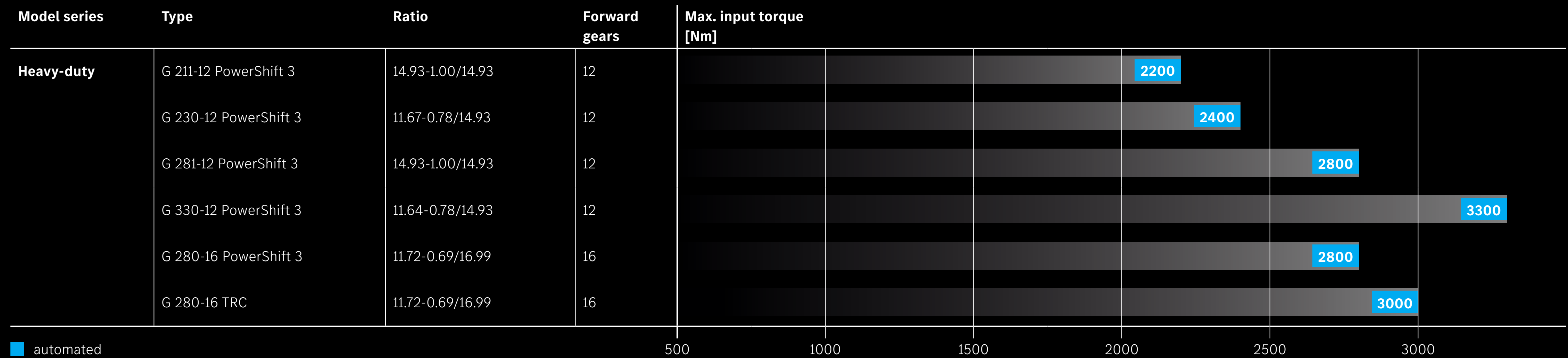

### Meaning of symbols:

**AMT** Fully automated manual transmission

 Transmissions for medium-duty trucks

 Transmission for heavy-duty trucks and special vehicles

 Transmission for cranes

Transmissions

# HEAVY-DUTY TRANSMISSIONS.





# HARD-WORKING AND RELIABLE.

## Your product benefits for heavy-duty transmissions:

- **12- to 16-speed** manual and automated shifted manual transmissions
- **Max. input torque** from **2200** to **3300 Nm**
- **Gear ratio** spread from **11.64** to **17.17**
- Max. permissible **gross combination weight (GCW)** from **44** to **60 t (250 t)**
- **Oil retarder** can be adapted
- Highly variable **modular systems** for customer-specific system solutions
- **Quiet running characteristics** and **long service life** through optimized gear set geometry and high-precision processing technologies
- **Compact design** and **weight-optimized** metal housing for ideal installation dimensions and an ideal power/weight ratio
- **Long service intervals** and **low operating costs** due to a **fuel-efficient design** optimized for customer-specific operating conditions
- More **comfortable vibration characteristics** due to integrated engine suspension on the transmission housing

# G 211-12 POWERSHIFT 3



- 12-speed none synchronized transmission with a wide gear ratio spread
- Direct-drive configuration
- Oil retarder can be adapted



## Specifications and dimensions

<b>Max. input torque</b>	2200 Nm
<b>Permissible gross combination weight (GCW)</b>	44 t
<b>Transmission weight excl. oil</b>	235 kg/ 299 kg*
<b>Oil filling capacity</b>	10 l
<b>A = length</b>	964 mm
<b>B = width</b>	596 mm
<b>C = centre to center</b>	142 mm

\* with retarder

Gear	1	2	3	4	5	6	R	Gear ratio spread
iS	14.930	9.024	5.628	3.393	2.051	1.279	14.930	14.93
iL	11.673	7.056	4.400	2.653	1.604	1.000	11.673	14.93

# G 230-12 POWERSHIFT 3



- 12-speed none synchronized transmission with a wide gear ratio spread
- Overdrive configuration
- Oil retarder can be adapted



## Specifications and dimensions

<b>Max. input torque</b>	2400 Nm
<b>Permissible gross combination weight (GCW)</b>	45 t
<b>Transmission weight excl. oil</b>	235 kg/ 299 kg*
<b>Oil filling capacity</b>	10 l
<b>A = length</b>	964 mm
<b>B = width</b>	596 mm
<b>C = centre to center</b>	142 mm

\* with retarder

Gear	1	2	3	4	5	6	R1	R2	Gear ratio spread
iS	11.673	7.056	4.400	2.653	1.604	1.000	11.673	2.653	14.97
iL	9.101	5.501	3.431	2.068	1.205	0.780	9.101	2.068	14.97

# G 281-12 POWERSHIFT 3



- 12-speed none synchronised transmission with a wide gear ratio spread
- Direct-drive configuration
- Oil retarder can be adapted

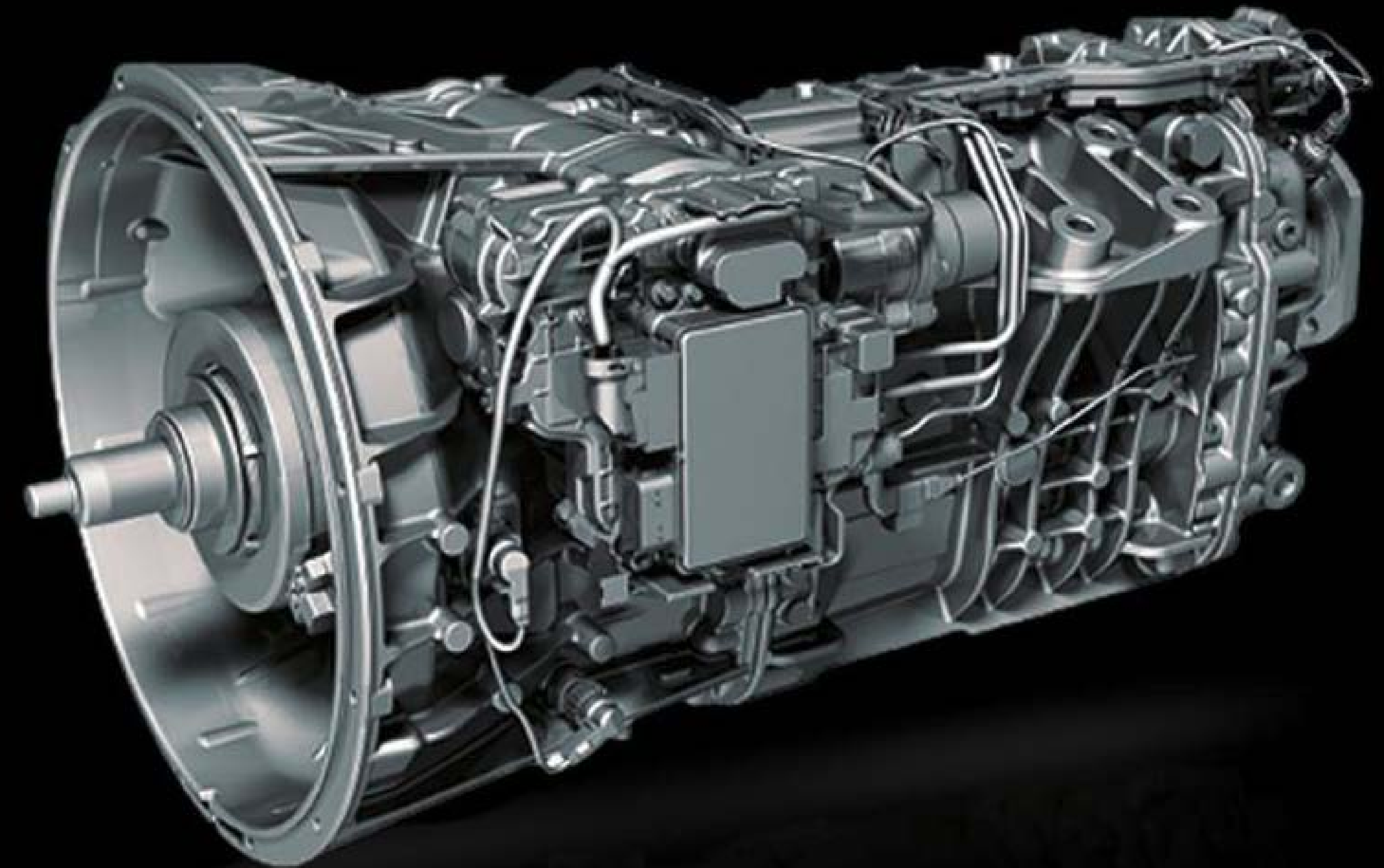

## Specifications and dimensions

<b>Max. input torque</b>	2800 Nm
<b>Permissible gross combination weight (GCW)</b>	60 t
<b>Transmission weight excl. oil*</b>	287 kg/ 351 kg*
<b>Oil filling capacity</b>	14 l
<b>A = length</b>	1033.5 mm
<b>B = width</b>	624 mm
<b>C = centre to center</b>	152 mm

\* with retarder

Gear	1	2	3	4	5	6	R1	R2	Gear ratio spread
iS	14.931	11.132	6.581	3.698	2.187	1.293	20.873	4.100	14.93
iL	14.563	8.611	5.091	2.861	1.691	1.000	16.145	3.171	14.93

# G 330-12 POWERSHIFT 3



- 12-speed none synchronized transmission with a wide gear ratio spread
- Overdrive configuration
- Oil retarder can be adapted

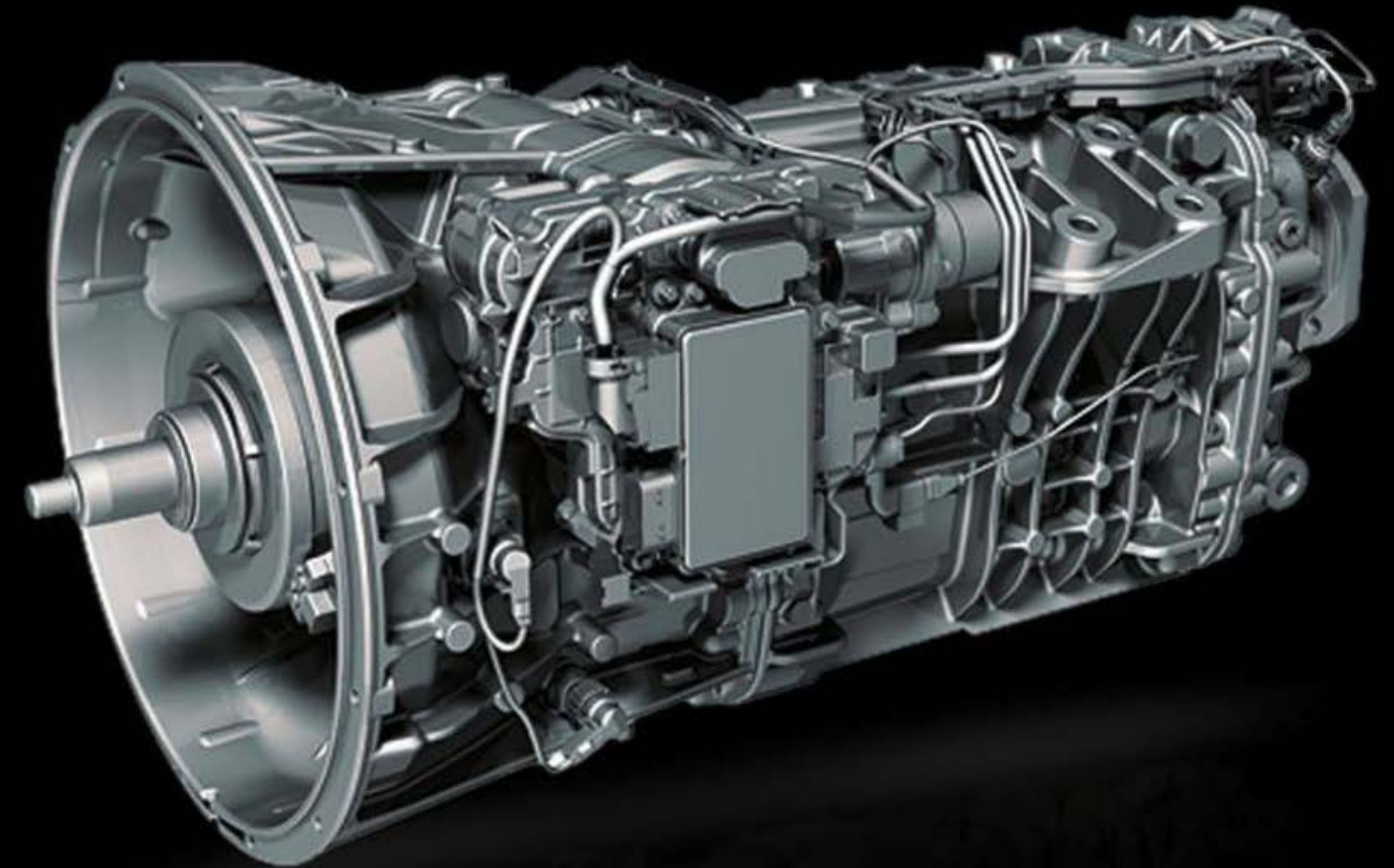

## Specifications and dimensions

<b>Max. input torque</b>	3300 Nm
<b>Permissible gross combination weight (GCW)</b>	60 t
<b>Transmission weight excl. oil</b>	287 kg/ 351 kg*
<b>Oil filling capacity</b>	14 l
<b>A = length</b>	1033.5 mm
<b>B = width</b>	624 mm
<b>C = centre to center</b>	152 mm

\* with retarder

Gear	1	2	3	4	5	6	R 1	R 2	Gear ratio spread
iS	11.639	7.035	4.400	2.645	1.599	1.000	12.774	2.093	15.02
iL	9.020	5.452	3.410	2.050	1.239	0.775	9.900	2.250	15.02

# G 280-16 POWERSHIFT 3



- 16-speed none synchronized transmission with a wide gear ratio spread
- Overdrive configuration
- Oil retarder can be adapted

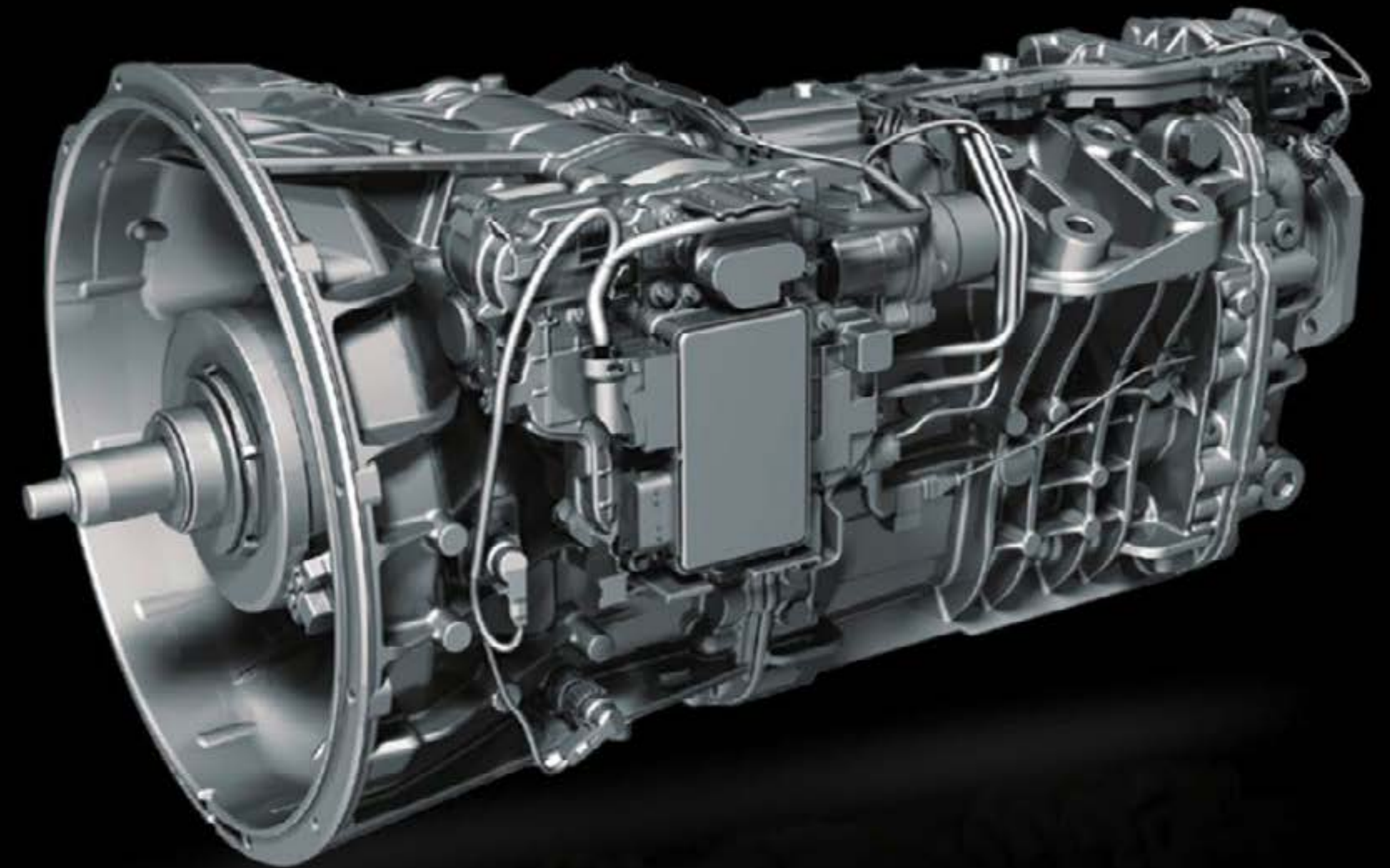

## Specifications and dimensions

<b>Max. input torque</b>	2800 Nm
<b>Permissible gross combination weight (GCW)</b>	60 t
<b>Transmission weight excl. oil</b>	294 kg/ 358 kg*
<b>Oil filling capacity</b>	14 l
<b>A = length</b>	1033.5 mm
<b>B = width</b>	624 mm
<b>C = centre to center</b>	152 mm

\* with retarder

Gear	1	2	3	4	5	6	7	8	R 1	R 2	Gear ratio spread
iS	11.722	7.916	5.291	3.636	2.664	1.799	1.203	0.826	10.656	2.422	17.06
iL	9.747	6.583	4.400	3.023	2.215	1.496	1.000	0.687	8.861	2.014	17.06

Transmissions

# TRC TRANSMISSION.



TRC transmission

# TRC TRANSMISSION FOR EXTREME APPLICATIONS.

## Automated non-synchronous transmission including TRC

The innovative TRC starting and braking element unites hydrodynamic start-up and hydrodynamic braking functions into one system. Unlike conventional torque converter solutions, engine output is transferred by a fill-level-regulated, fluid turbo coupling.

- Wear-free start-up and manoeuvring due to the hydrodynamic transfer of power with no time limit due to variable turbo coupling input.
- In conjunction with the large gear ratio spread, it is possible to manoeuvre heavy loads with millimetre precision, even when tractional resistance is high.
- Braking with no wear due to integrated primary retarder function and patented coupling configuration.





TRC transmission

# G 280-16 TRC



- 16-speed non-synchronous transmission with a wide gear ratio spread
- Overdrive configuration

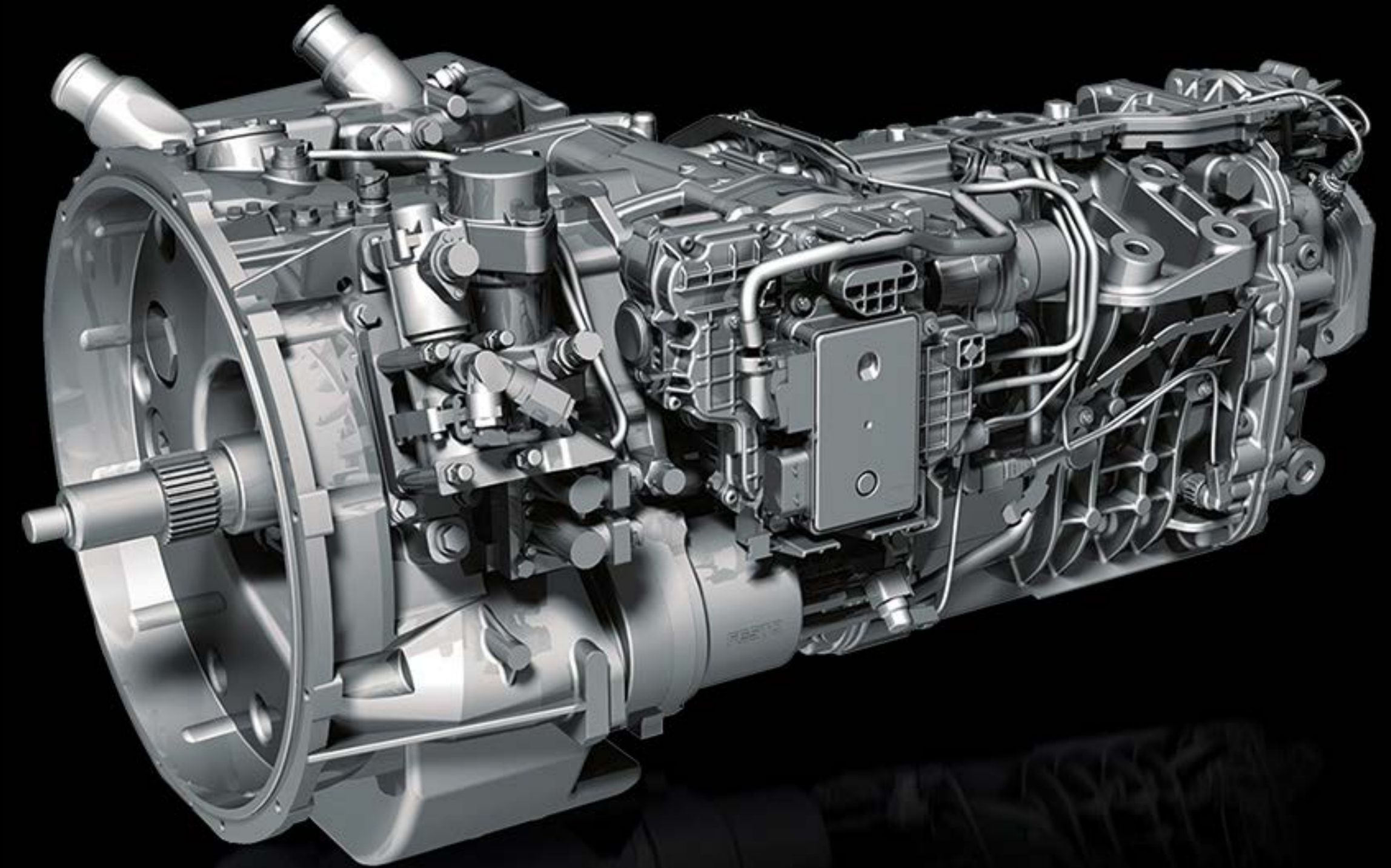

## Specifications and dimensions

<b>Max. input torque</b>	3000 Nm
<b>Permissible gross combination weight (GCW)</b>	250 t
<b>Transmission weight excl. oil</b>	455 kg
<b>Oil filling capacity</b>	13.5 l
<b>A = length</b>	1200 mm
<b>B = width</b>	690 mm
<b>C = centre to center</b>	152 mm

Gear	1	2	3	4	5	6	7	8	R 1	R 2	Gear ratio spread
<b>Ratio</b>	11.722	7.916	5.291	3.636	2.664	1.799	1.203	0.826	10.656	2.422	17.06
<b>Ratio</b>	9.747	6.583	4.400	3.023	2.215	1.496	1.000	0.687	8.861	2.014	17.06

Transmissions

# RETARDER.



Retarder

## INTEGRATED OIL RETARDER.

The braking power of the retarder is also independent of selected gear or current engine speed.

A gear change does **not** result in **any interruption** in the retarder braking action and the retarder braking power depends only on the current driving speed.

The braking power can be controlled precisely in **five stages** using the right-hand control stalk on the steering column. In addition to the engine brake, the retarder provides a **maximum braking torque of up to 3500 Nm.**

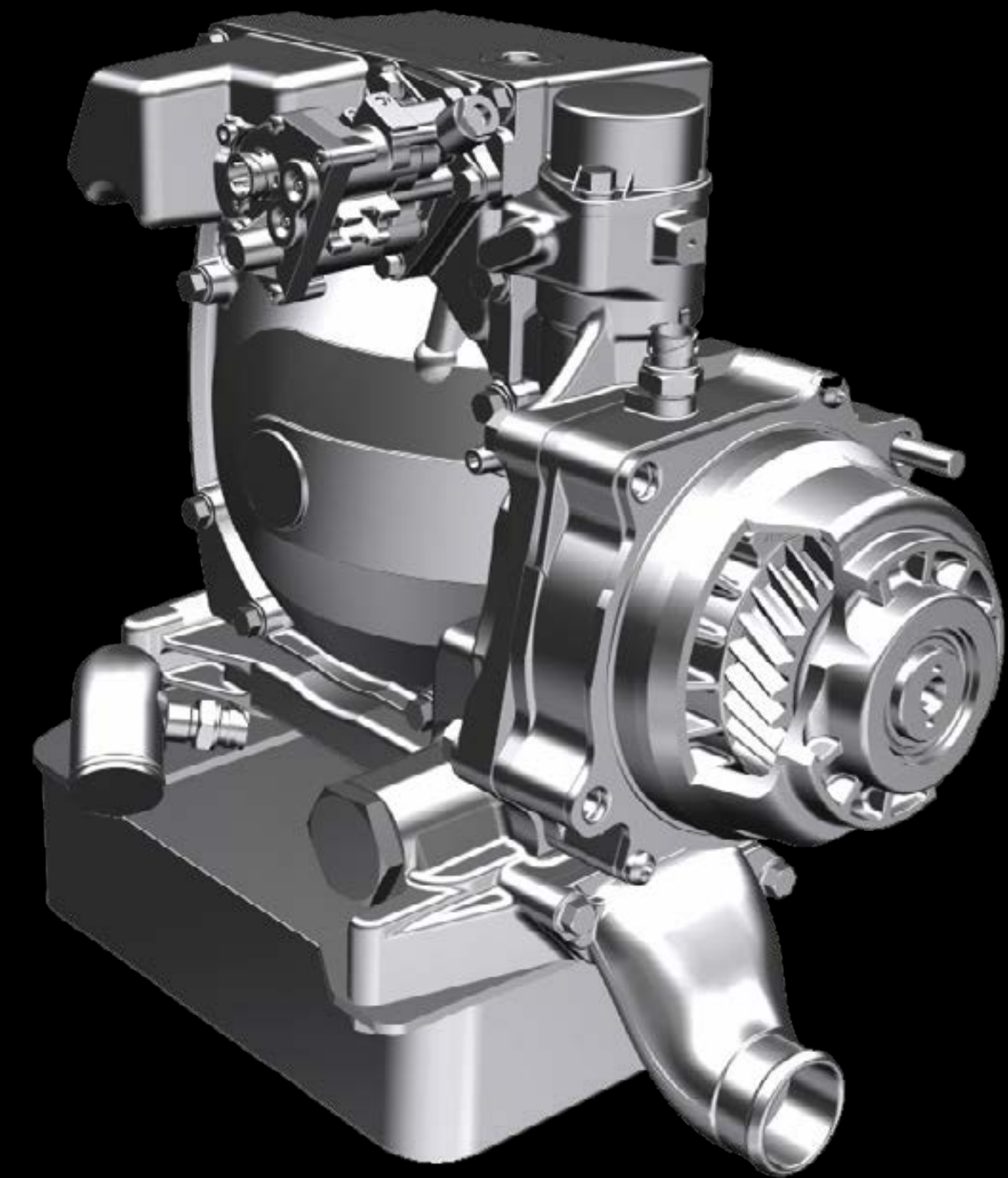

# INTEGRATED OIL RETARDER.\*

## Your product benefits:

- Integrated **step-up gear retarder**
- **High braking moments**
- **Autarchic oil supply system**
- **Stainless steel heat exchanger**
- **Oil-air separation**
- **Optimized hydrodynamics**
- Retarder **integrated into the vehicle management system**
- Standard universal joint shaft length **is not affected by the retarder**

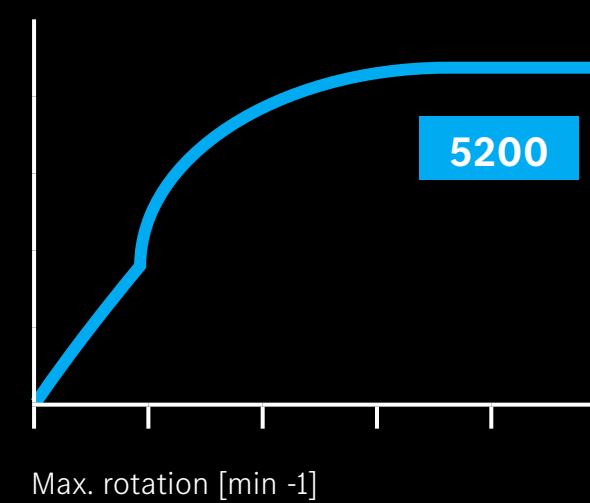
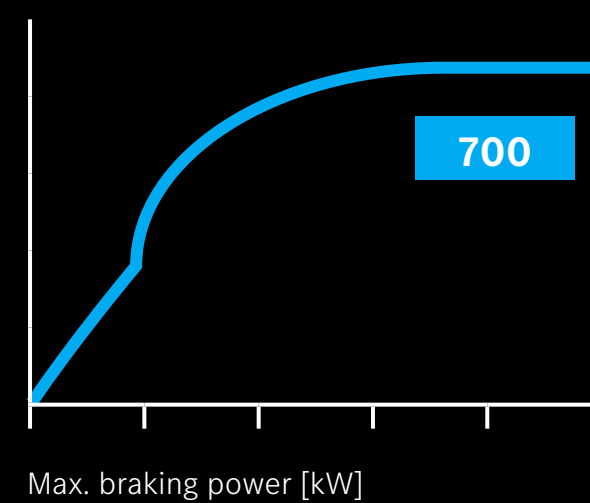
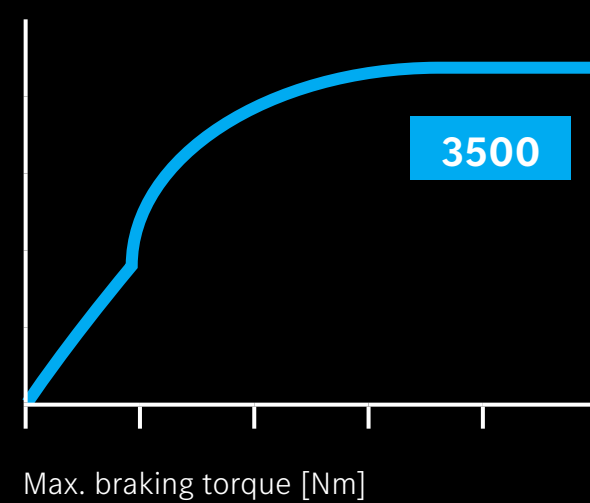

\* Not available with TRC

# DERIVATION “NOMENCLATURE” - TRANSMISSIONS.

**G** = transmissions

**Number** = gears

**G**

**280**

**6/-16**

**K**

**PowerShift 3**

**TRC**

**90** = Maximum torque/  
10 [900 Nm]  
**330** = Maximum torque/  
10 [3300 Nm]

**K** = Non  
synchronized  
transmission  
**S** = Synchronized  
transmission

**PowerShift 3** =  
Automated gearshift

**TRC** = Turbo retarder  
clutch  
**VR 115 HV** =  
Oil retarder

---

# AXLES

Reliable axles  
for every application.

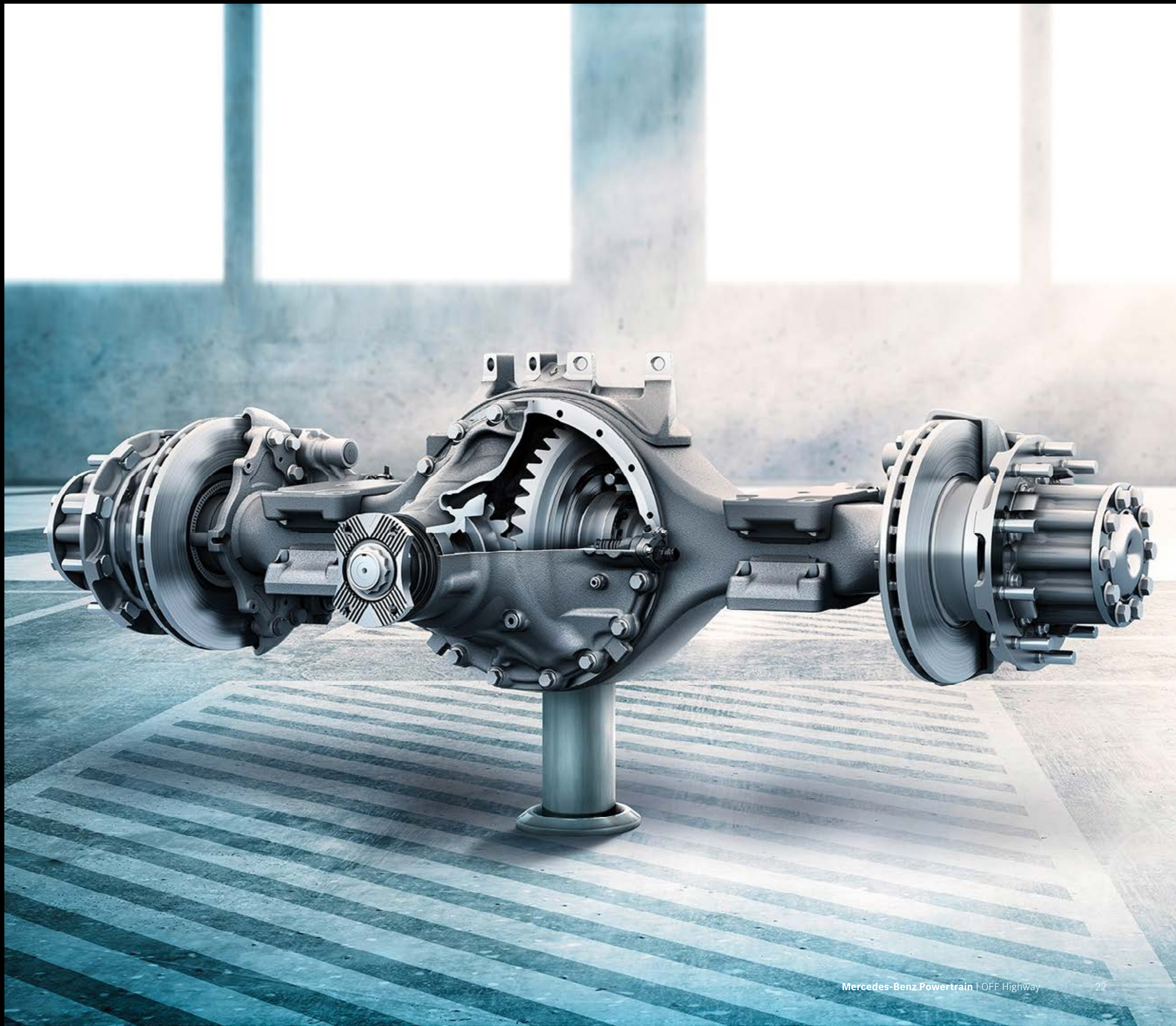

# THE MOST EFFICIENT WAY OF PUTTING POWER ON THE ROAD.

Our product range consists of axles for a broad range of commercial vehicles. This portfolio is highly suitable for nearly all commercial categories, in urban areas or overland, from delivery to heavy-duty trucks.

We use our customers' experience, requirements and demands as an essential precondition for the development of new axle technologies.

Our innovative state-of-the-art engineering and our quality-driven plants in Germany give our axles outstanding performance in:

- **Durability**
- **Fuel efficiency**
- **Quiet operation**

Top vehicle manufacturers around the world trust the outstanding quality and performance of our axles and the

reliability of our services. We are one of the world's biggest producers of commercial axles and we want to share our experience and technology with you.

See for yourself and discover the advantages of Mercedes-Benz axles.



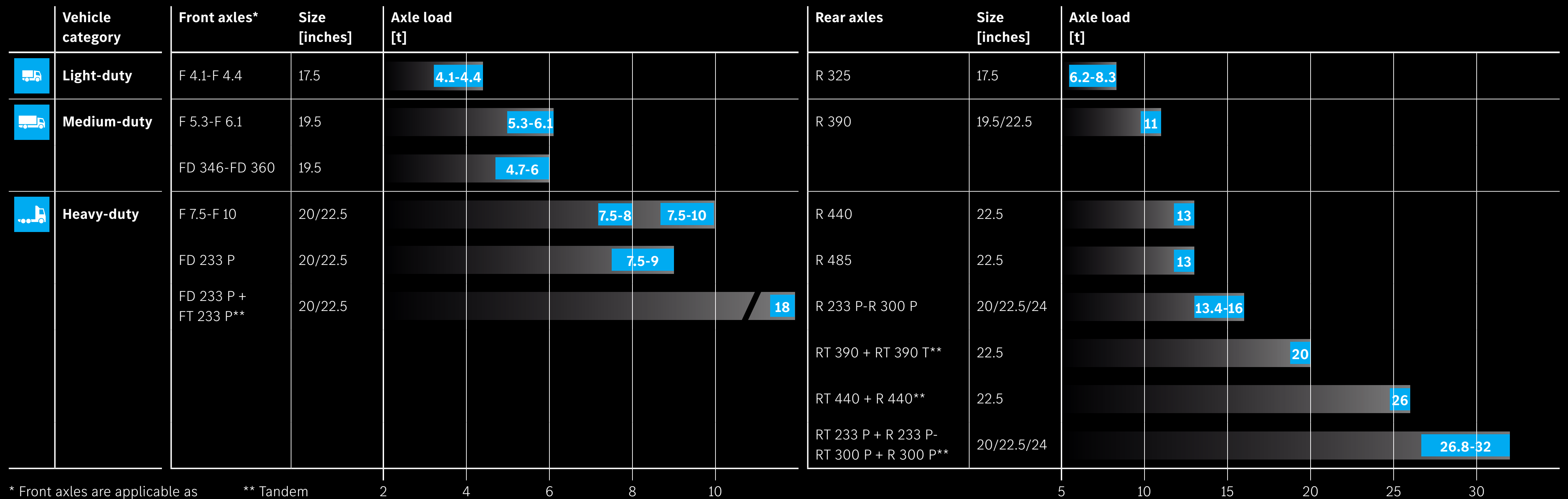

# THE RIGHT AXLE FOR EVERY APPLICATION.

**Axle portfolio:** front axles\* and rear axles



**Meaning of symbols:**

- FA Front axles
- RA Rear axles
-  Axles for light-duty trucks
-  Axles for medium-duty trucks
-  Axles for heavy-duty trucks



Axles

# FRONT AXLES.



# FLEXIBILITY AT A HIGH LEVEL.

## Your product benefits for front axles:

- **Wheel-end sizes** from **17.5** to **22.5 inches**
- Driven front axles **for light-, medium- and heavy-duty applications**
- **Axle loads** from **4.1** to **10 t** (per axle)
- **Gross vehicle weight rating (GVWR)** from **6.5** to **250 t**
- **Additional payload** due to compact design and weight-optimized technical design
- **Left- or right-hand drive** applications possible
- **High-fuel-efficiency design** to suit the operating conditions
- **Maintenance-free** wheel hubs
- Easy maintenance and **long oil change intervals**
- **Longer lifetime** and **quieter operation** due to our optimized gear set design

Front axles

# F 4.1-F 4.4

FA



- Steered rigid axle with forged front axle beam
- Recommended for light-duty application



## Data and dimensions

<b>Axle load</b>	4.1-4.4 t
<b>Wheel-end size</b>	17.5 inches
<b>Brake</b>	disk brake
<b>Axle weight*</b>	245 kg
<b>A = overall width</b>	2293-2303 mm
<b>B = track width</b>	1949-1975 mm
<b>C = spring track</b>	830 mm
<b>D = max. steering angle</b>	52°

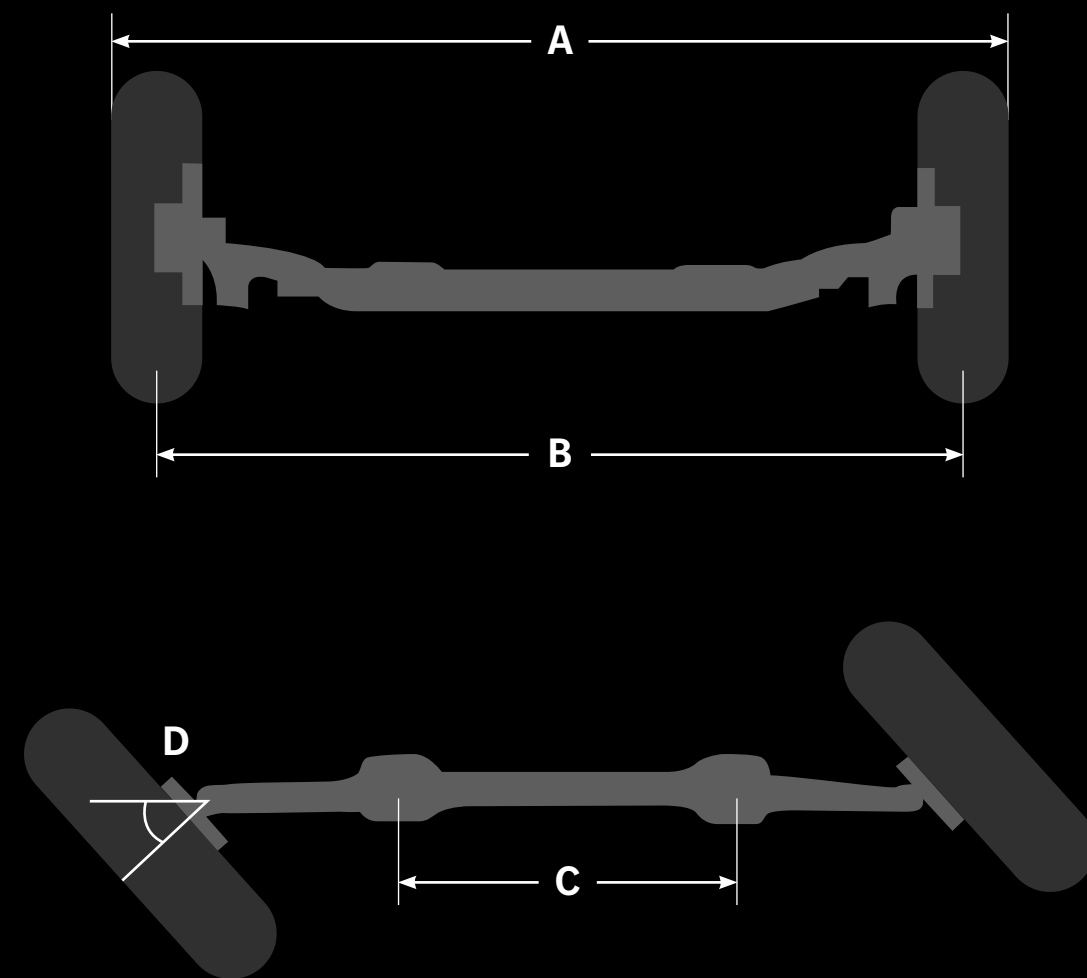

\* varies depending on configuration

Front axles

# F 5.3-F 6.1

FA



- Steered rigid axle with forged front axle beam
- Recommended for medium-duty application



## Data and dimensions

<b>Axle load</b>	5.3-6.1 t
<b>Wheel-end size</b>	19.5 inches
<b>Brake</b>	disk brake
<b>Axle weight*</b>	357 kg
<b>A = overall width</b>	2346-2389 mm
<b>B = track width</b>	1955-1991 mm
<b>C = spring track</b>	830 mm
<b>D = max. steering angle</b>	52°

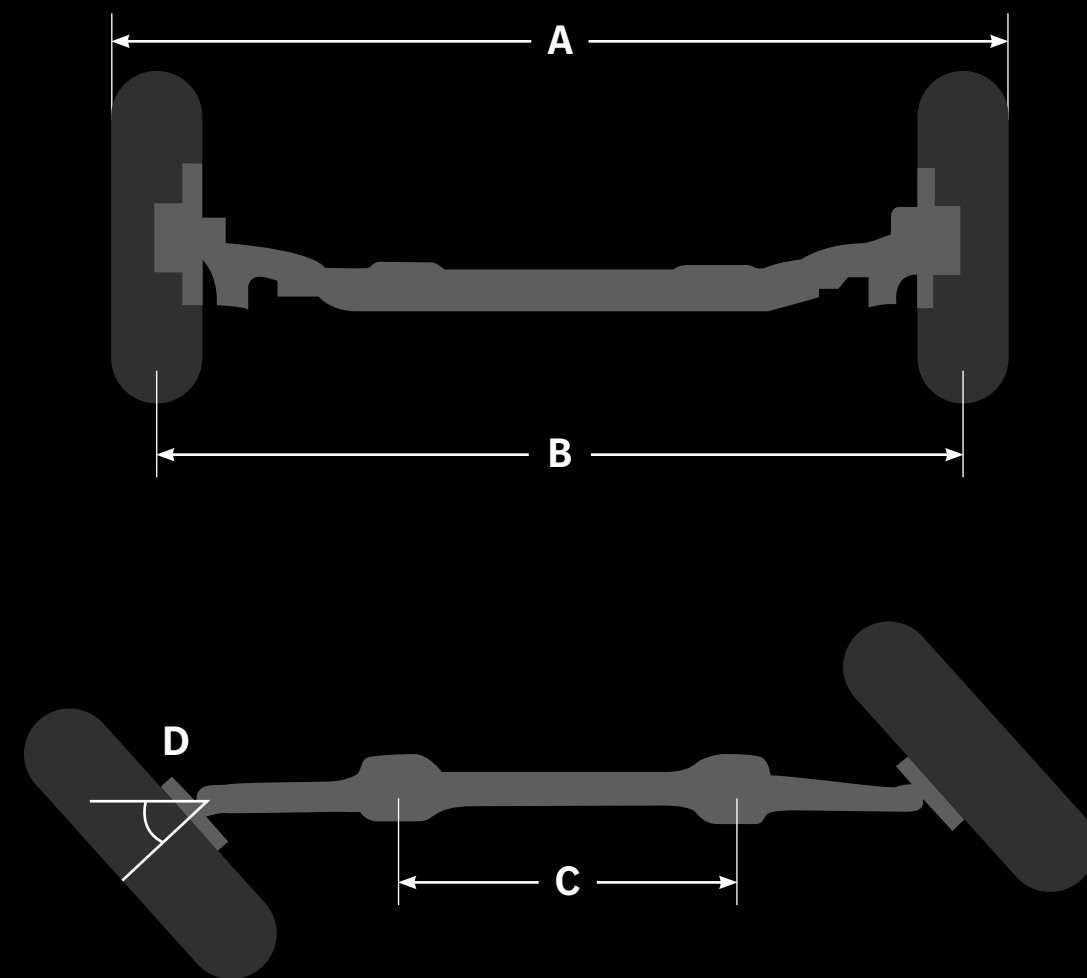

\* varies depending on configuration

Front axles

# FD 346-FD 360

FA



- Steered, driven salisbury-design axle
- Recommended for medium-duty application



## Data and dimensions

<b>Axle load</b>	4.7-6 t
<b>Wheel-end size</b>	19.5 inches
<b>Brake</b>	drum brake
<b>Drive type</b>	single-stage
<b>Axle weight*</b>	492 kg

<b>A = overall width</b>	2190-2496 mm
<b>B = track width</b>	1886-2098 mm
<b>C = spring track</b>	830/1000 mm
<b>D = max. steering angle</b>	39°

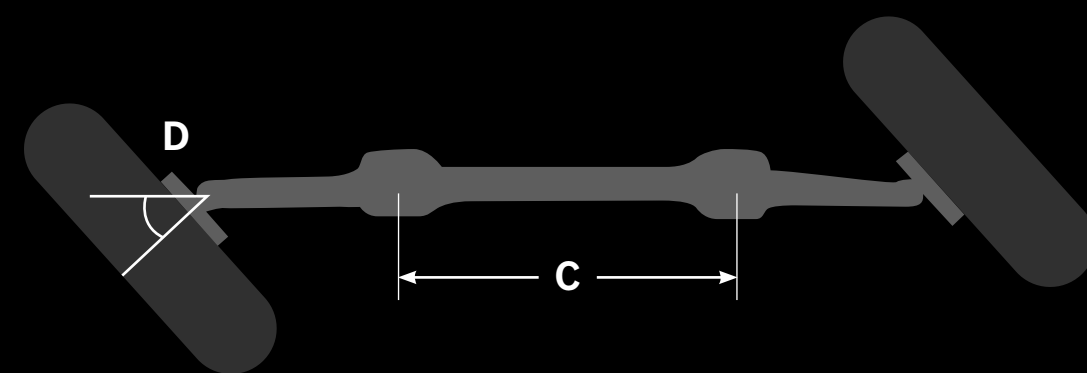
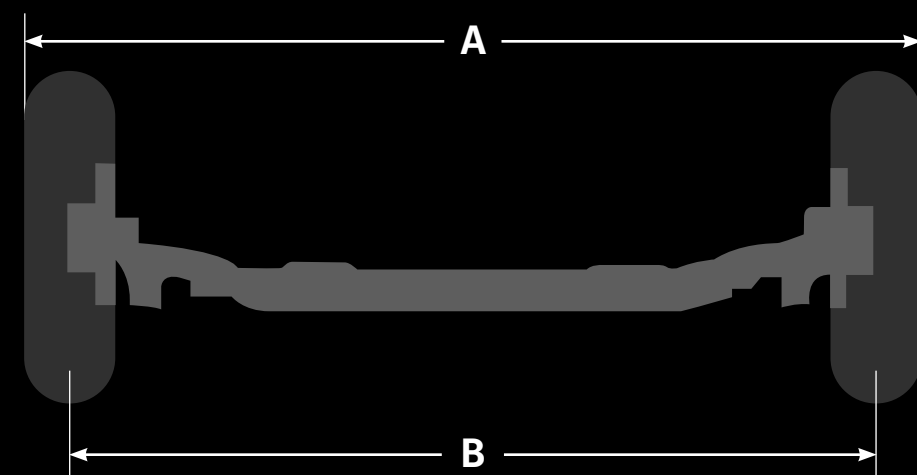

\* varies depending on configuration

Front axles

# F 7.5-F 10



- Steered rigid axle with forged front axle beam
- Recommended for heavy-duty application



## Data and dimensions

<b>Axle load</b>	7.5-10 t
<b>Wheel-end size</b>	22.5 inches
<b>Brake</b>	disk brake/drum brake
<b>Axle weight*</b>	463 kg
<b>A = overall width</b>	2486-2583 mm
<b>B = track width</b>	2046-2153 mm
<b>C = spring track</b>	840 mm
<b>D = max. steering angle</b>	48°

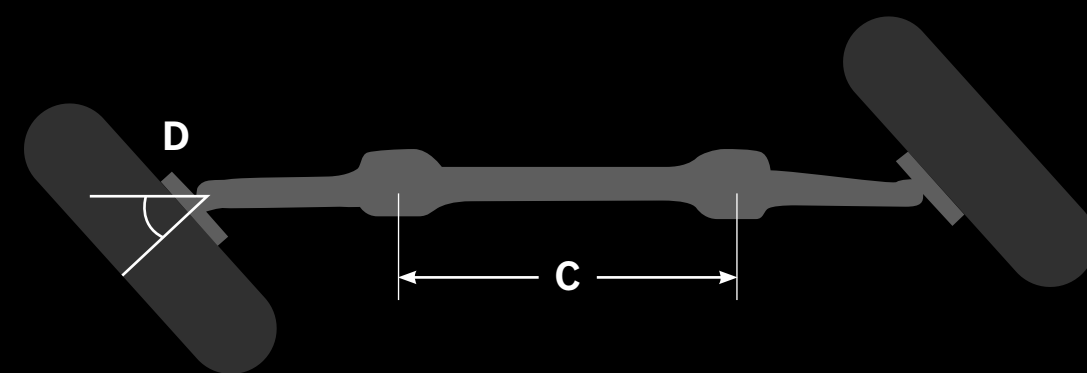
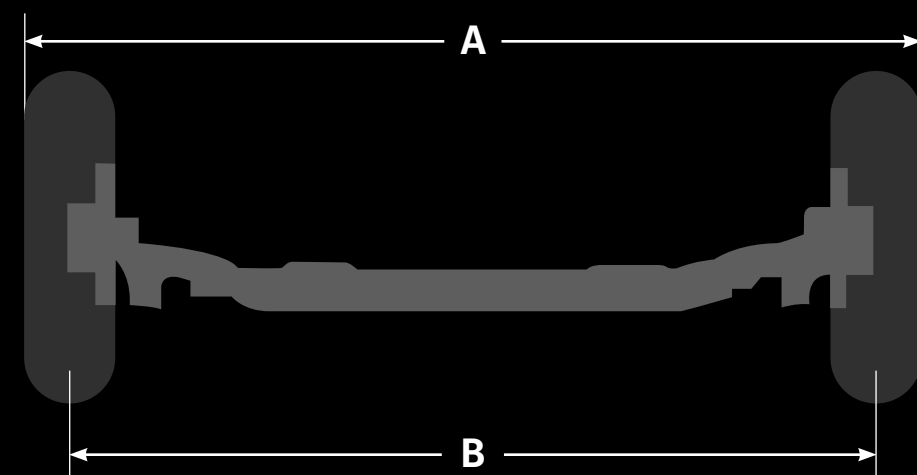

\* varies depending on configuration

Front axles

# FD 233 P



- Steered, driven planetary axle with cast axle housing
- Recommended for heavy-duty application



## Data and dimensions

<b>Axle load</b>	7.5-9 t
<b>Wheel-end size</b>	22.5 inches
<b>Brake</b>	drum brake
<b>Drive type</b>	double reduction/planetary
<b>Axle weight*</b>	738 kg

<b>A = overall width</b>	2480-2506 mm
<b>B = track width</b>	1997-2092 mm
<b>C = spring track</b>	840/875 mm
<b>D = max. steering angle</b>	42°

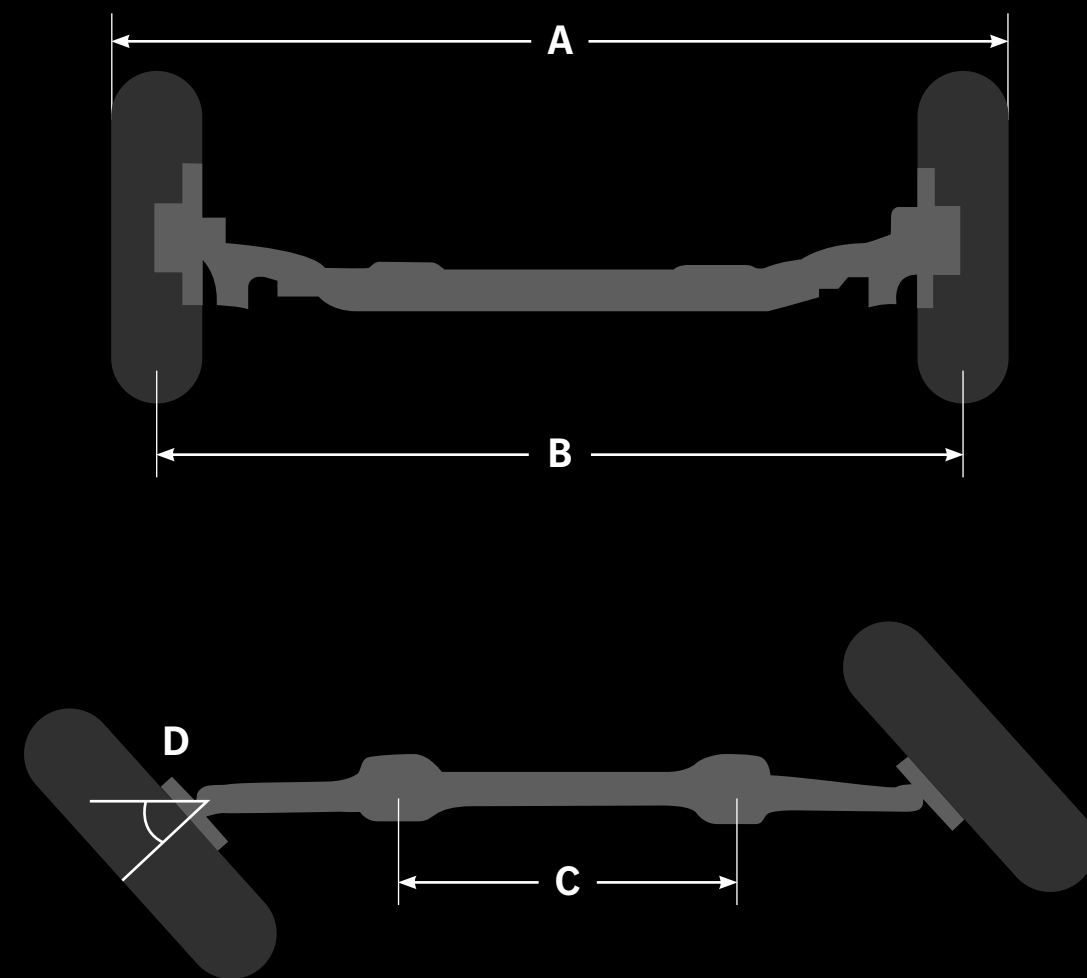

\* varies depending on configuration

Front axles

# FD 233 P + FT 233 P

FA



- Steered, driven planetary axle with cast axle housing, tandem
- Recommended for heavy-duty application



## Data and dimensions

<b>Axle load</b>	18 t (tandem)
<b>Wheel-end size</b>	22.5 inches
<b>Brake</b>	drum brake
<b>Through-drive axle</b>	yes
<b>Drive type</b>	double reduction/ planetary
<b>Axle weight*</b>	1621 kg
<b>A = overall width</b>	2480-2506 mm
<b>B = track width</b>	1997-2092 mm
<b>C = spring track</b>	840 mm
<b>D = max. steering angle</b>	38°

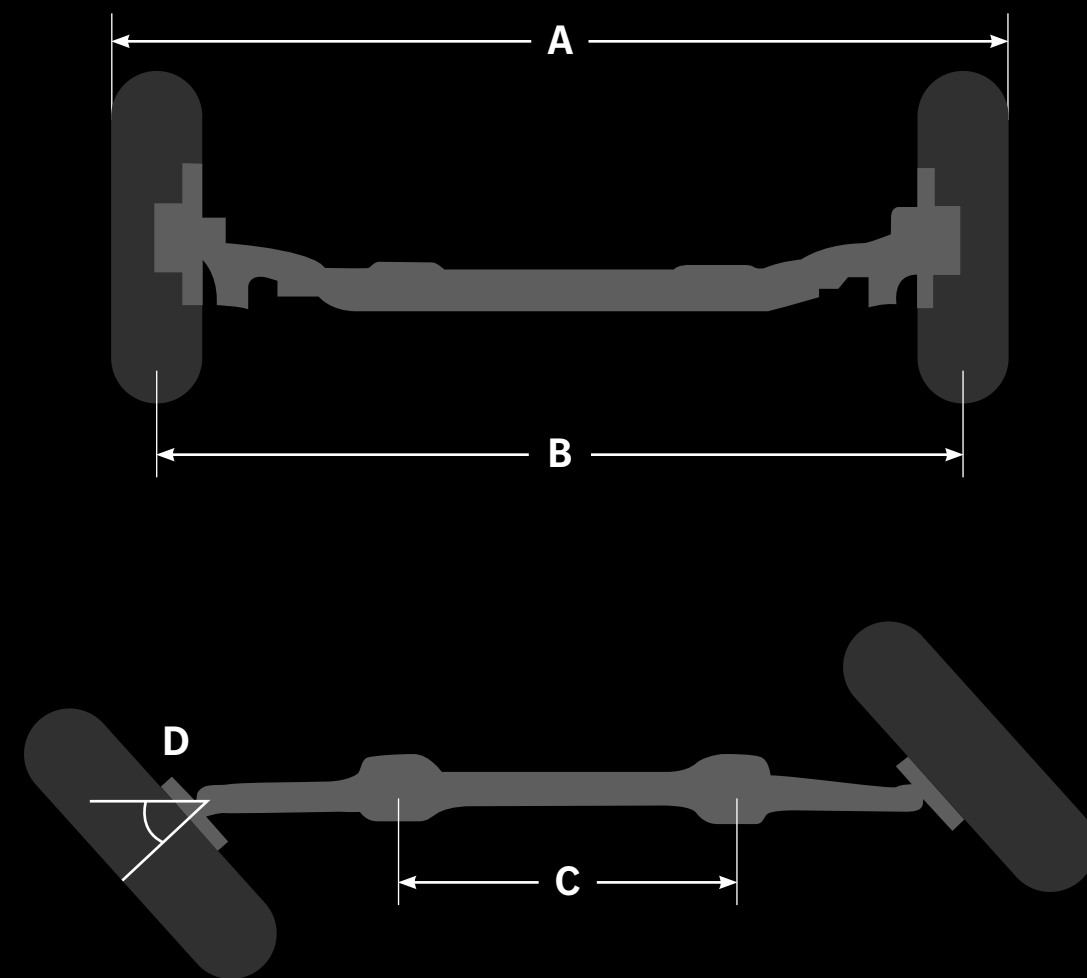

\* varies depending on configuration



Axles

# REAR AXLES.



# MASTER EVERY CHALLENGE.

## Your product benefits for rear axles:

- **Wheel-end sizes** from **17.5** to **22.5 inches**
- **Hypoid- and planetary-driven**
- **Ring gear diameter** from **233** to **485 mm**
- **Axle loads** from **6.2** to **16 t** (per axle)
- **Gross vehicle weight rating (GVWR)** from **6.5** to **250 t**
- **High fuel efficiency**
- **Easy maintenance** and long oil change intervals
- **Long lifetime** and **quiet operation** due to optimized gear set design
- **Additional payload** due to weight-optimized design
- **Maintenance-free** wheel hub
- New final drive axle with **optimized oil management** reduces fuel consumption

Rear axles

# R 325

RA



- Fabricated axle housing
- Recommended for light-duty application



## Data and dimensions

<b>Axle load</b>	6.2-8.3 t
<b>Wheel-end size</b>	17.5 inches
<b>Brake</b>	disk brake
<b>Suspension</b>	air springs/steel springs
<b>Drive type</b>	single reduction/hypoid
<b>Axle weight*</b>	350 kg
<b>A = overall width</b>	2232-2330 mm
<b>B = track width</b>	760-1775 mm
<b>C = spring track</b>	1022 mm
<b>Ring gear diameter</b>	325 mm

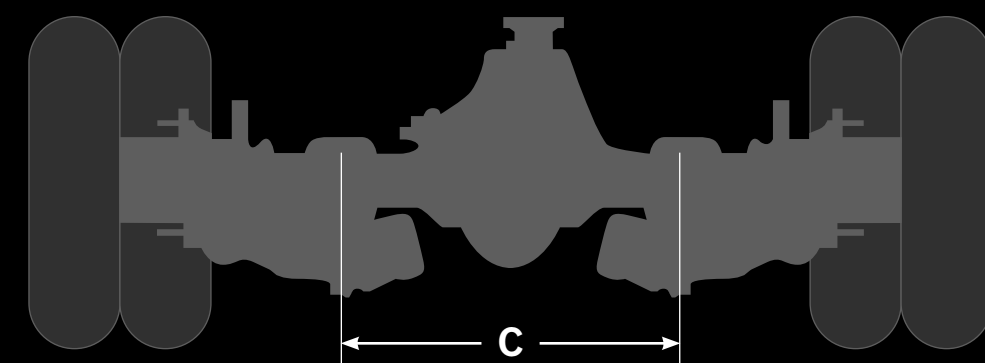
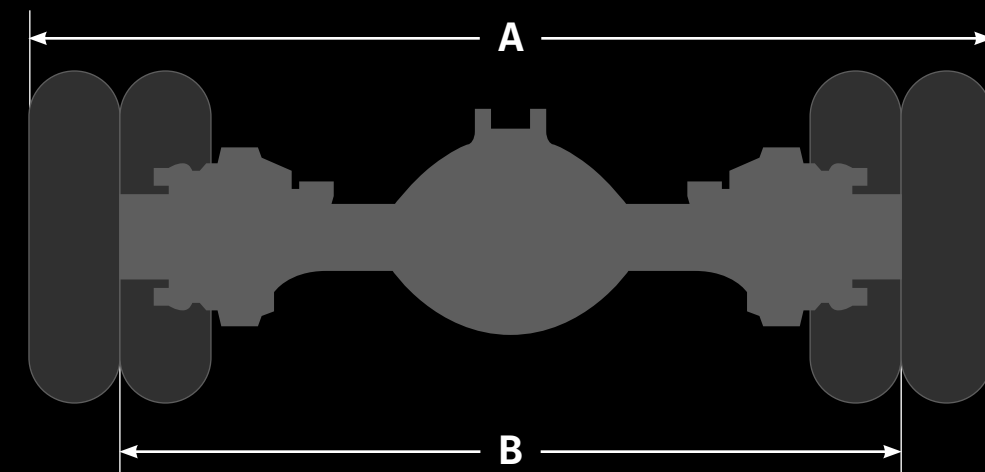

\* varies depending on configuration

Rear axles

# R 390

RA



- Fabricated axle housing
- Recommended for medium-duty application



## Data and dimensions

<b>Axle load</b>	7.7 - 11t*
<b>Wheel-end size</b>	19.5 inches
<b>Brake</b>	disk brake/drum brake
<b>Suspension</b>	air springs/steel springs
<b>Drive type</b>	single reduction/hypoid
<b>Axle weight**</b>	541 kg
<b>A = overall width</b>	2284-2489 mm
<b>B = track width</b>	1753-1840 mm
<b>C = spring track</b>	1022 mm
<b>Ring gear diameter</b>	390 mm

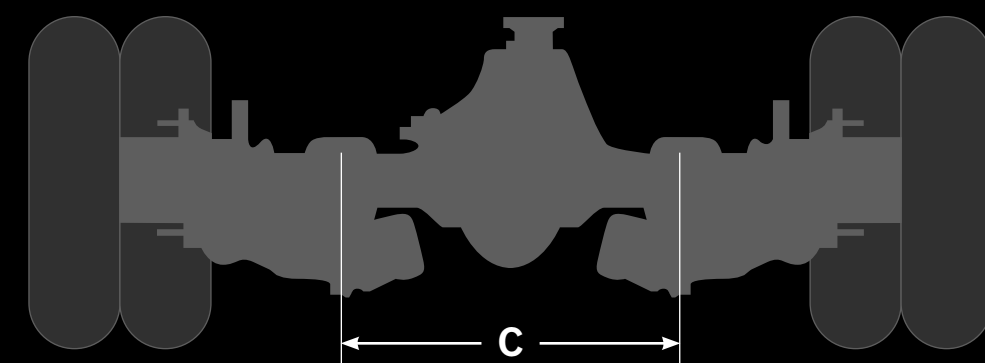
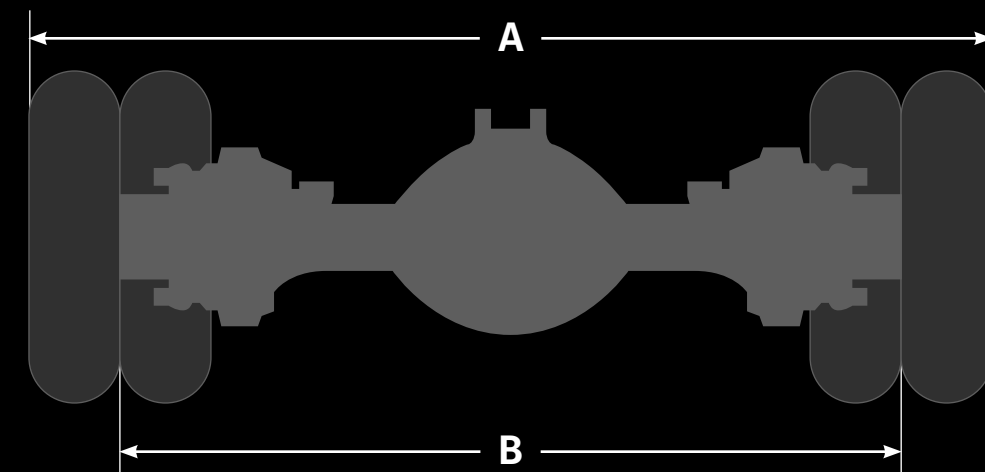

\* 7.7 t single tire  
9.2 t swiss width  
\*\* varies depending on configuration

# R 440

RA



- Fabricated axle housing
- Recommended for heavy-duty application



## Data and dimensions

<b>Axle load</b>	13 t
<b>Wheel-end size</b>	22.5 inches
<b>Brake</b>	disk brake
<b>Suspension</b>	air springs/steel springs
<b>Drive type</b>	single reduction/hypoid
<b>Axle weight*</b>	680 kg
<b>A = overall width</b>	2410-2482 mm
<b>B = track width</b>	1802-1910 mm
<b>C = spring track</b>	930 mm
<b>Ring gear diameter</b>	440 mm

\* varies depending on configuration

# R 485

RA



- Cast axle housing for high engine torque
- Recommended for heavy-duty application

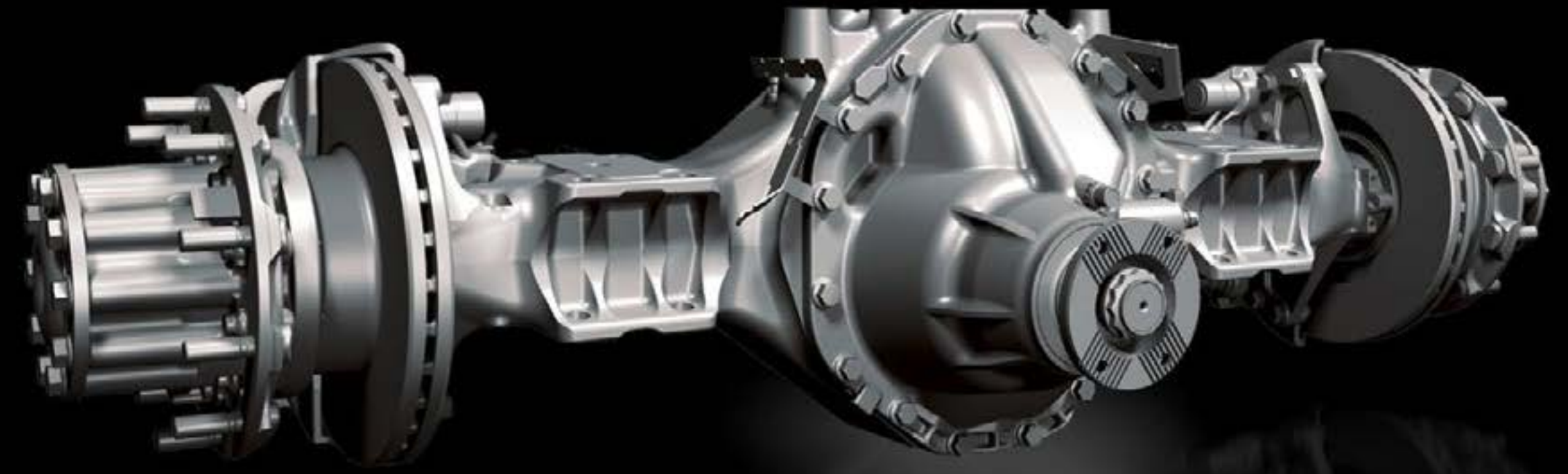

## Data and dimensions

<b>Axle load</b>	13 t
<b>Wheel-end size</b>	22.5 inches
<b>Brake</b>	disk brake
<b>Suspension</b>	air springs/steel springs
<b>Drive type</b>	single reduction/hypoid
<b>Axle weight*</b>	765 kg
<b>A = overall width</b>	2422-2482 mm
<b>B = track width</b>	1802-1804 mm
<b>C = spring track</b>	930 mm
<b>Ring gear diameter</b>	485 mm

\* varies depending on configuration

Rear axles

# R 233 P-R 300 P

RA



- Planetary axle with cast axle housing
- Recommended for heavy-duty application

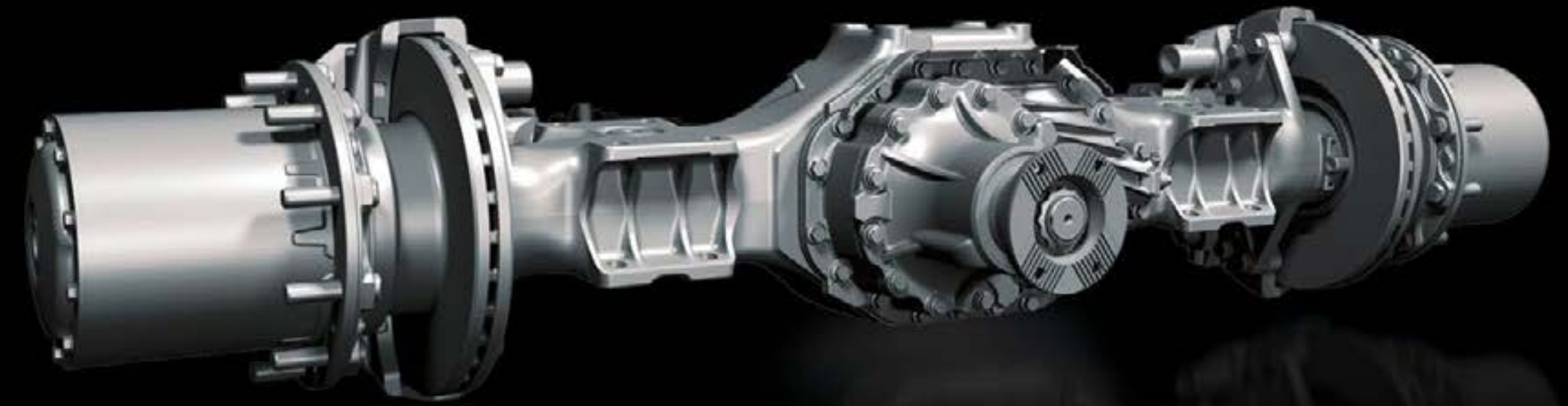

## Data and dimensions

<b>Axle load</b>	13.4-16 t
<b>Wheel-end size</b>	22.5 inches
<b>Brake</b>	disk brake/drum brake
<b>Suspension</b>	air springs/steel springs
<b>Drive type</b>	double reduction/planetary
<b>Axle weight*</b>	792 kg
<b>A = overall width</b>	2407-2775 mm
<b>B = track width</b>	1800-2039 mm
<b>C = spring track</b>	930 mm
<b>Ring gear diameter</b>	233/300 mm

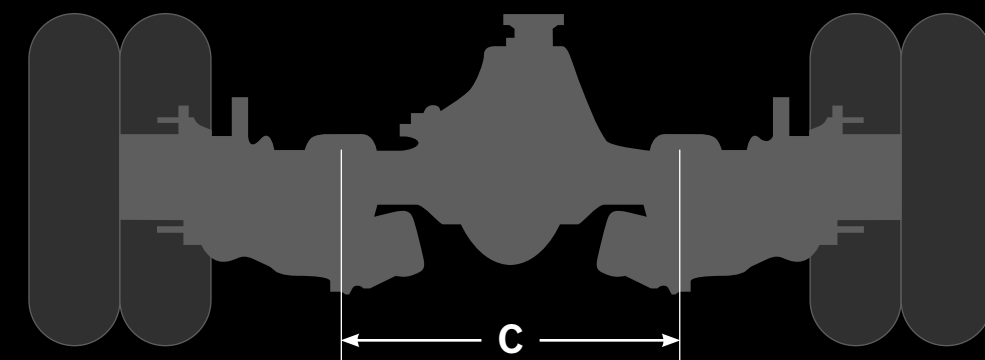
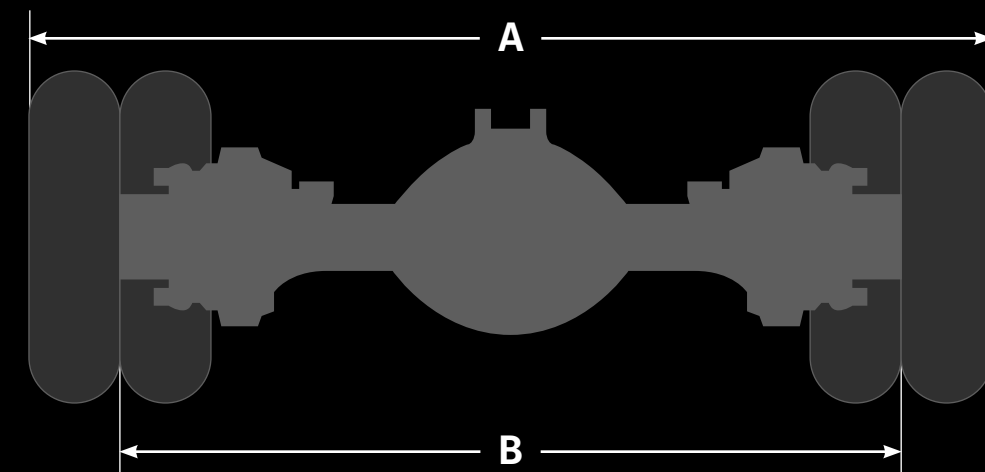

\* varies depending on configuration

Rear axles

# RT 233 P + R 233 P

# RT 300 P + R 300 P

RA



- Planetary axle with cast axle housing, tandem
- Recommended for heavy-duty application



## Data and dimensions

<b>Axle load</b>	26.8-32 t (tandem)
<b>Wheel-end size</b>	22.5 inches
<b>Brake</b>	disk brake/drum brake
<b>Through-drive axle</b>	yes
<b>Suspension</b>	air springs/steel springs
<b>Drive type</b>	two-stage/planetary
<b>Axle weight*</b>	1643 kg (tandem)
<b>A = overall width</b>	2407-2775 mm
<b>B = track width</b>	1800-2039 mm
<b>C = spring track</b>	930 mm
<b>Ring gear diameter</b>	233/300 mm

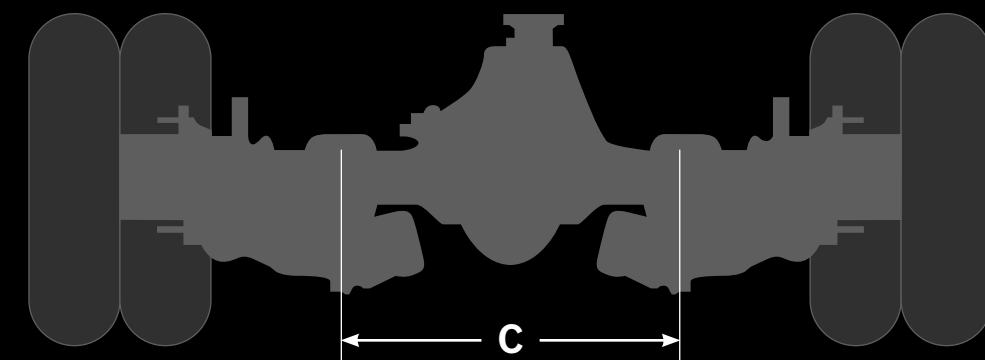
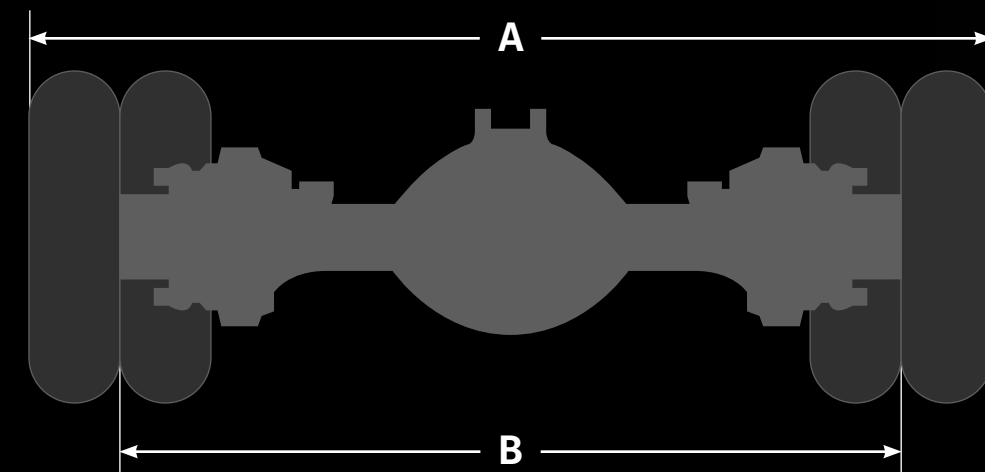

\* varies depending on configuration



Rear axles

# RT 390 + RT 390 T

RA



- Fabricated axle housing, tandem
- Recommended for heavy-duty application



## Data and dimensions

<b>Axle load</b>	20 t (tandem)
<b>Wheel-end size</b>	22.5 inches
<b>Brake</b>	disk brake
<b>Through-drive axle</b>	yes
<b>Suspension</b>	air springs/steel springs
<b>Drive type</b>	single-stage/hypoid
<b>Axle weight*</b>	1220 kg (tandem)
<b>A = overall width</b>	2442-2502 mm
<b>B = track width</b>	1824 mm
<b>C = spring track</b>	930 mm
<b>Ring gear diameter</b>	390 mm

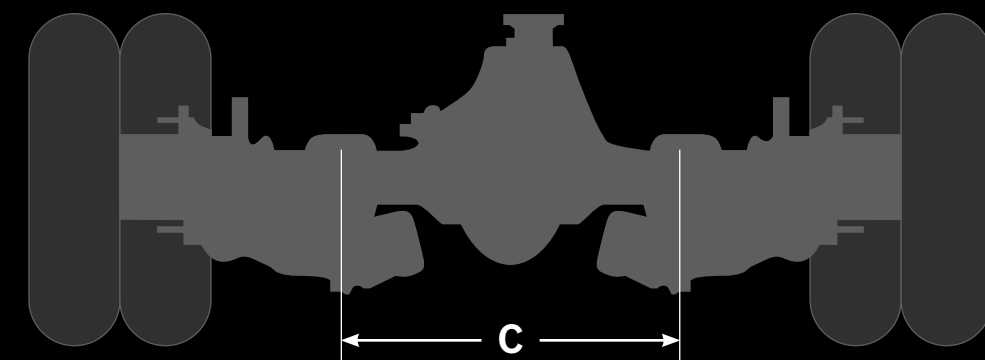
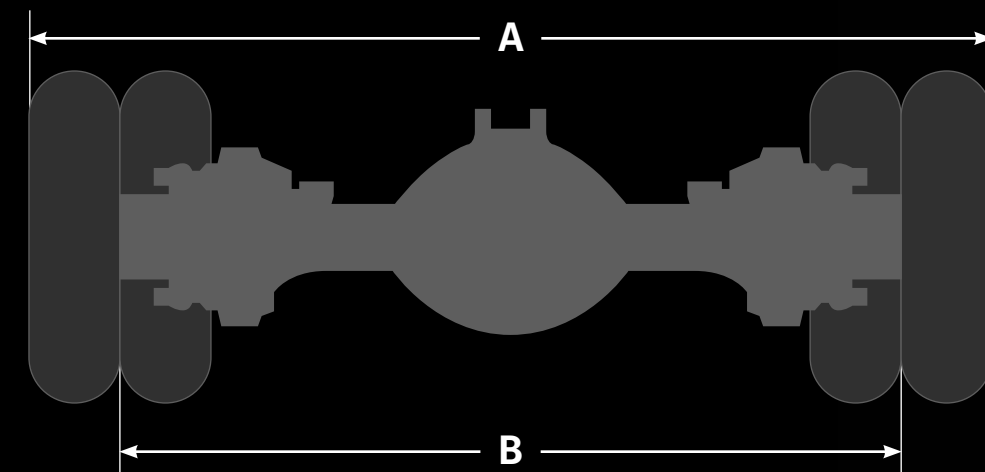

\* varies depending on configuration

Rear axles

# RT 440 + R 440

RA



- Fabricated axle housing, tandem
- Recommended for heavy-duty application



## Data and dimensions

<b>Axle load</b>	26 t (tandem)
<b>Wheel-end size</b>	22.5 inches
<b>Brake</b>	disk brake
<b>Through-drive axle</b>	yes
<b>Suspension</b>	air springs/steel springs
<b>Drive type</b>	single-stage/hypoid
<b>Axle weight*</b>	1482 kg (tandem)
<b>A = overall width</b>	2410-2482 mm
<b>B = track width</b>	1802-1910 mm
<b>C = spring track</b>	930 mm
<b>Ring gear diameter</b>	440 mm

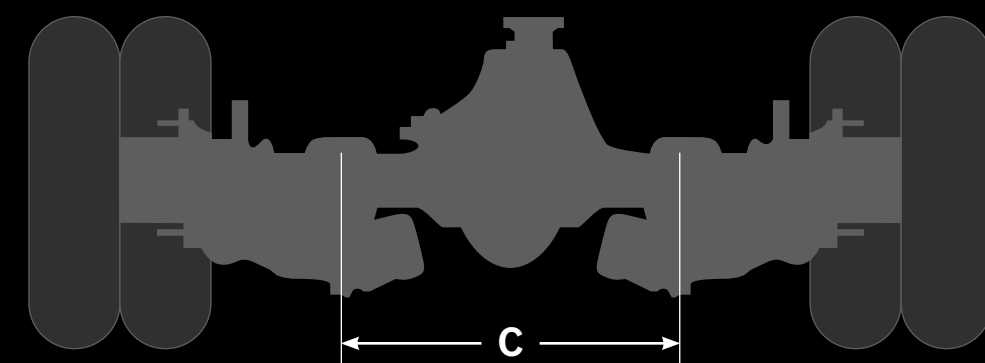
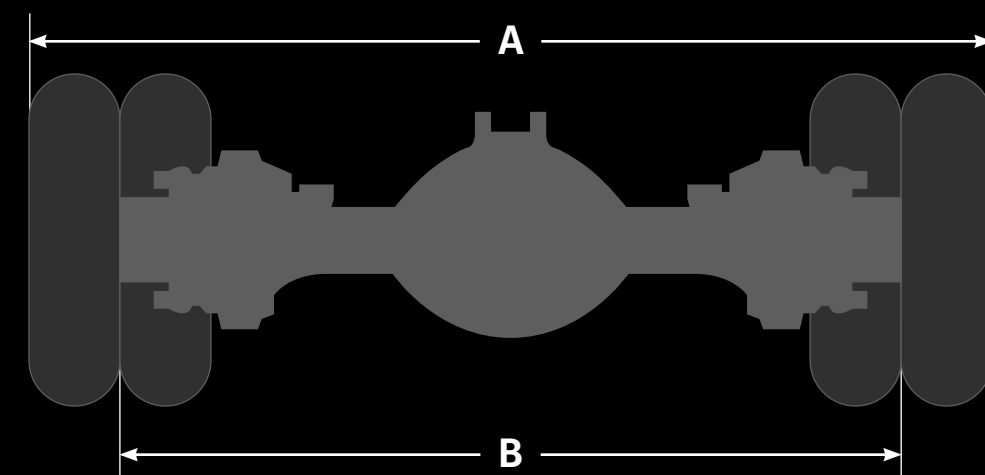

\* varies depending on configuration

# DERIVATION “NOMENCLATURE” - AXLES.

## Non-driven axles

**F** = Front axle

**F**

**9**

**Number** =  
Axle load [t]

## Driven axles

**R** = Rear axle

**RT** = Rear axle tandem

**FD** = Front axle driven

**FT** = Front axle tandem driven

**R**

**440**

**Number** =  
Ring gear  
diameter [mm]

---

# SERVICE

More than products.



Service

# OUR GLOBAL MERCEDES-BENZ SERVICE NETWORK.

Optimizing customer support while minimizing downtimes of your trucks and buses is highly relevant for us. Enjoy the advantages of our network with more than 2,400 authorized Mercedes-Benz Truck Service Centers worldwide.



Your nearest Service Center:  
Dealer Locator Online



Service

# SPARE PARTS SUPPLY.

We will ensure spare parts availability for many years after your initial investment. Your vehicle can only deliver top performance if it's kept in shape at all times. It is only the use of high-quality GenuineParts that ensures that the explicit and implied warranty is maintained.

For our price-sensitive customers, we also offer a large portfolio of Genuine Remanufactured Parts – to save costs but maintain the same quality level.



Service

# MORE THAN PRODUCTS.

Our perfectly matched powertrain delivers you the best possible performance and fuel savings, while maintaining low overall operating costs. The perfect combination of engine systems, transmissions and axles yields the greatest possible efficiency and the best quality made by Mercedes-Benz Powertrain. We tailor Mercedes-Benz Powertrain component configurations to the needs of our customers for sales in the on-highway segment.

**If you have technical questions, would like additional information or wish to request installation drawings, please do not hesitate to contact our sales team.**

Sales External Customers  
Daimler Truck AG  
HPC DTF3B  
70771 Leinfelden-Echterdingen  
Germany

[powertrain.mercedes-benz-trucks.com](http://powertrain.mercedes-benz-trucks.com)

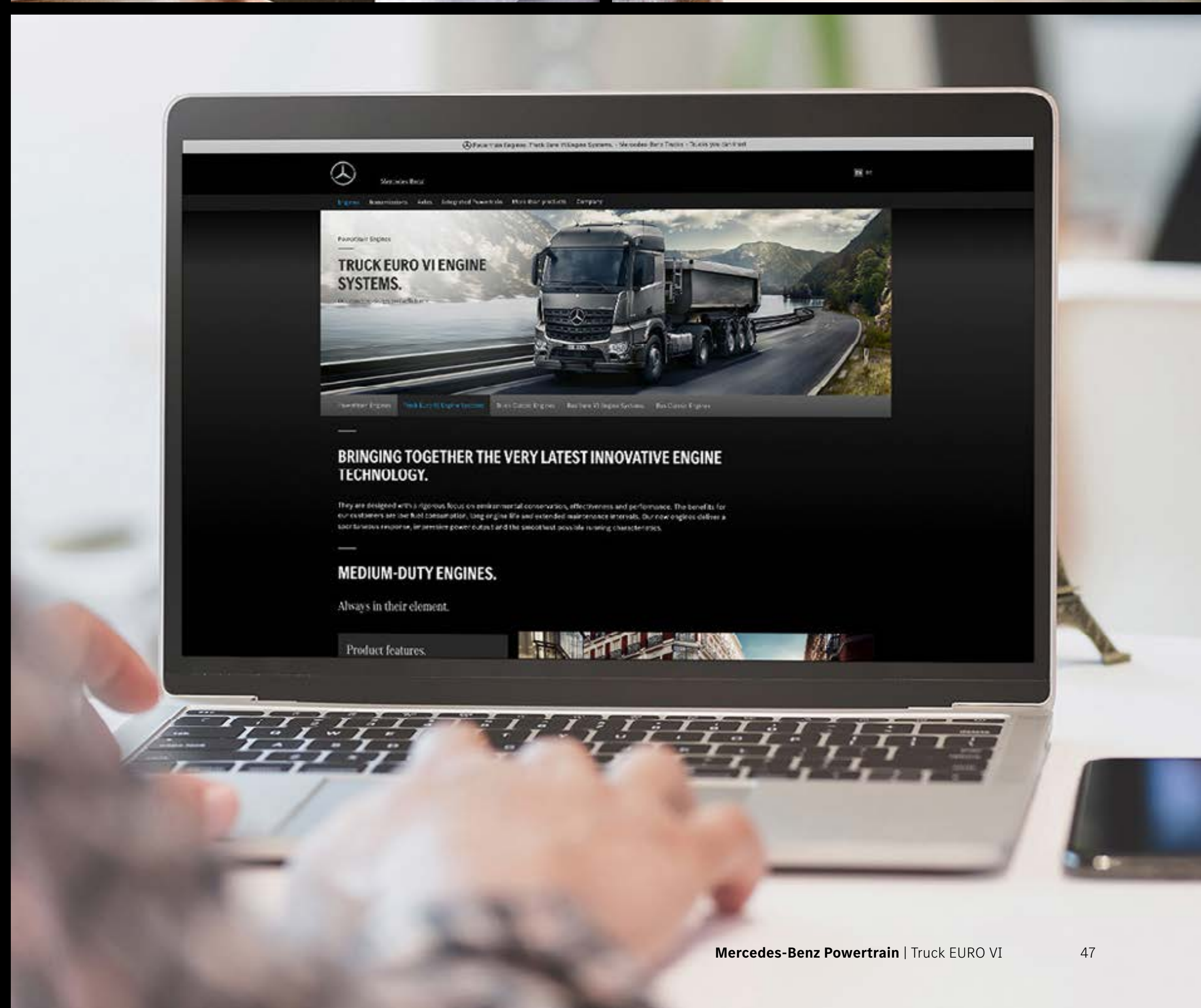
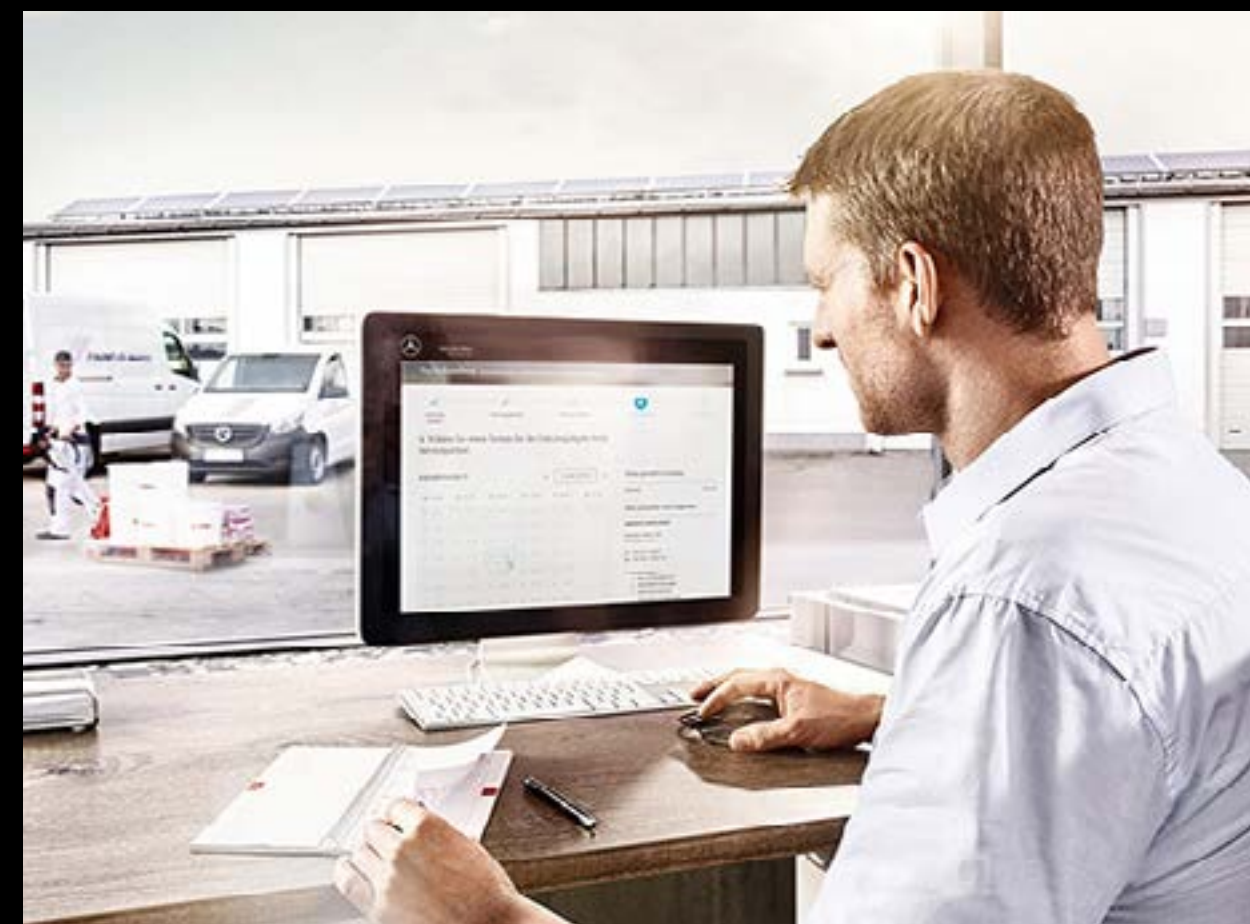

# INDEX

Components at a glance.





Index

# TRANSMISSIONS.

Type	Ratio	Forward gears	Max. input torque [Nm]	TRUCKS	BUSES
GO 250-8 PowerShift 3	6.57-0.63/10.38	8	2500		X
G 211-12 PowerShift 3	14.93-1.00/14.93	12	2200	X	
G 230-12 PowerShift 3	11.67-0.78/14.93	12	2400	X	
G 281-12 PowerShift 3	14.93-1.00/14.93	12	2800	X	
G 330-12 PowerShift 3	11.64-0.78/14.93	12	3300	X	
G 280-16 PowerShift 3	11.72-0.69/16.99	16	2800	X	
G 280-16 TRC	11.72-0.69/16.99	16	3000	X	

# RETARDER.

	TRUCKS	BUSES
Oil Retarder VR 115 HV	X	

# AXLES.

Type [front axles]	Wheel-end size [inches]	Axle load [t]	TRUCKS	BUSES
F 4.1-F 4.4	17.5	4.1-4.4	X	X
F 5.3-F 6.1	19.5	5.3-6.1	X	X
FD 346-FD 360	19.5	4.7-6	X	
FO 7.5	22.5	7.5		X
F 7.5-F 10	22.5	7.5-10	X	X
FD 233 P	22.5	7.5-9	X	
FD 233 P + FT 233 P	22.5	18	X	

Type [rear axles]	Wheel-end size [inches]	Axle load [t]	TRUCKS	BUSES
R 325	17.5	6.2-8.3	X	X
R 390	19.5/22.5	11	X	X
R 440	22.5	11.5-13	X	X
R 485	22.5	13	X	
R 233 P-R 300 P	22.5	13.4-16	X	
RT 233 P + R 233 P-RT 300 P + R 300 P	22.5	26.8-32	X	
RT 390 + RT 390 T	22.5	20	X	
RT 440 + R 440	22.5	26	X	

09/2024

Please note: changes may have been made to the products since this publication was published (09/2022). The manufacturer reserves the right to make changes to the design, form, colour and specification during the delivery period, provided these changes, while taking into account the interests of the vendor, can be deemed reasonable with respect to the purchaser. Where the vendor or the manufacturer uses symbols or numbers to describe an order or the subject of an order, no rights may be derived solely from these. The illustrations may show accessories and items of optional equipment which are not part of the standard specification. Colours may differ slightly from those shown, owing to the limitations of the printing process. This publication is distributed internationally. It may contain products and services which are not available in certain countries. Information given regarding statutory regulations, legal requirements and taxation and the consequences thereof applies to the Federal Republic of Germany only and is correct at the time of publication.

Daimler Truck AG, Fasanenweg 10, 70771 Leinfelden-Echterdingen, Germany, TT/LPS

5330 · 8000 · 01 · 01/0924

 and Mercedes-Benz are trademarks of Mercedes-Benz Group AG.